

ATC1250

PORTABLE STORAGE REELS ON WHEELS



Standard Configuration Shown

- Direct crank rewind.
- One-piece foot, rubber tires, and removable steel handlebar.
- A larger version of the C1150 model with pneumatic tires and a 4-1/2" x 9" (114 mm x 229 mm) drum opening.
- Supplied with a spring tension brake.

For:

- Industrial Maintenance
- Construction
- Agriculture
- Grounds Maintenance

Model Number	Hose Capacity of Reel feet m.				Approx. Weight lb. kg.	
	Gauge/Number of Conductors				NET	SHIP
	O.D. (in) O.D. (mm)	16/3 .390 10	14/3 .530 14	12/3 .600 15		
ATC1250	1800 549	950 290	750 229	550 168	84 38	89* 40

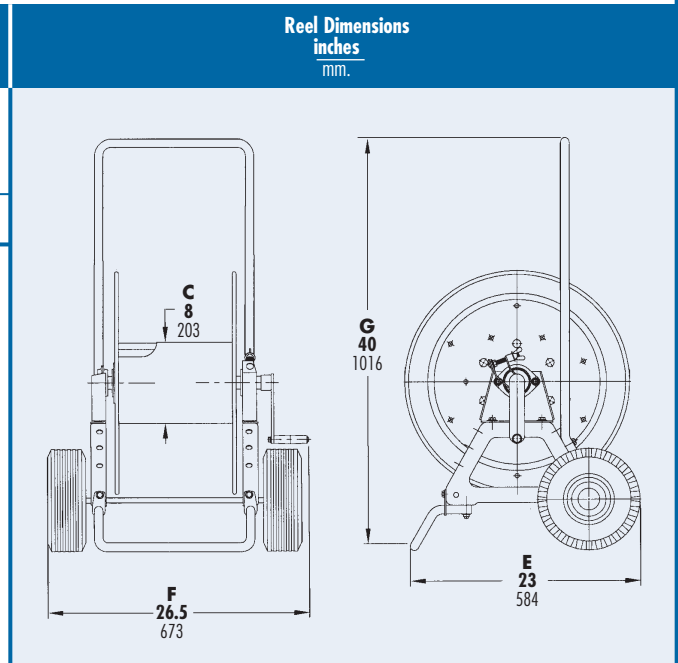

Notes:

1. Specifications subject to change.
 2. When ordering specify model number, O.D., length and weight of cable, hose, etc.
 3. For a detailed parts breakdown drawing, request ISO 87.
 4. **Finish:** refer to Page 4.
 5. **Be sure to check dimensions and weights prior to ordering.**
- * When shipped as a parcel package (via Fed-Ex or UPS Ground), some assembly required.