

FAMILY OWNED AND OPERATED SINCE 1933

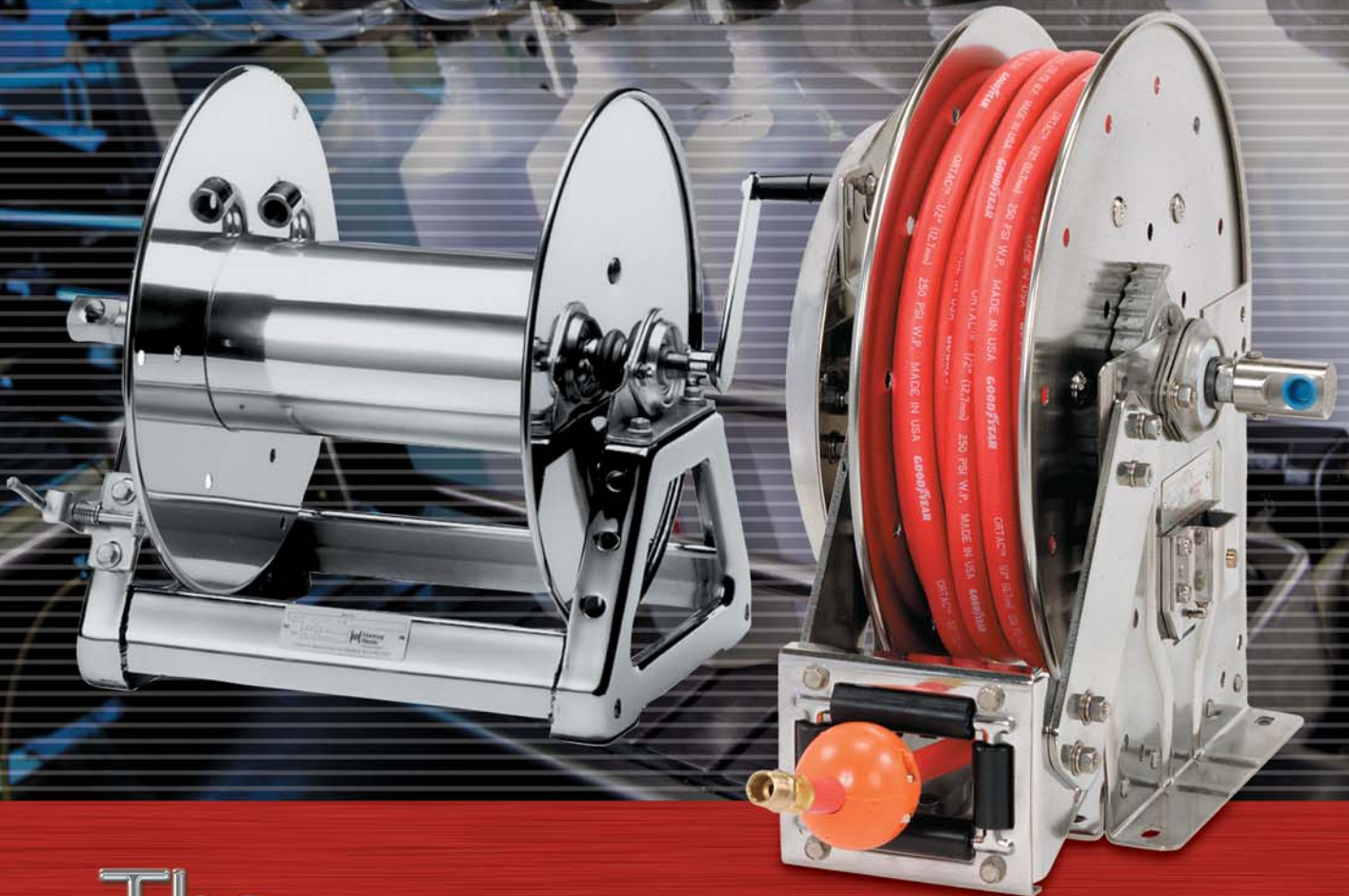

Hannay Reels®
The reel leader.

Stainless Steel Reels



The
Hannay
Way

Washdown • Chemical Transfer • Potable Water
Food Processing • Pharmaceuticals & Cosmetics • Fueling
Fire Protection • Dairy Operations • Bottling Plants

www.hannay.com

Pride in workmanship • Reels built to order • Consistent quality • Service with integrity • Value for your dollar

Hannay stainless steel reels offer protection against contamination and corrosion.

For sanitary or harsh environments, Hannay stainless steel reels are the reels of choice. These reels are invaluable in the food and beverage, dairy, pharmaceutical, and cosmetics industries due to their resistance to rust and corrosion and the absence of paint to chip. They also have numerous uses in marine and offshore settings. Applications for these reels include washdown, chemical transfer, potable water, food ingredient transfer, fueling, and fire protection.

Hannay Reels has been making stainless steel reels for over 30 years on a custom basis and has a wider selection than any other manufacturer. This catalog features some of our more popular stainless steel hose reels, including popular narrow-frame models that are ideal in confined spaces, compact reel models that are perfect for pressure washing, and rugged, heavy-duty models often used in industrial off-shore settings. The reels handle from 1/4" to 1" I.D. hose and, depending on the model, are available in either manual or spring rewind.

At your request, almost any of our standard hose or cable models can be constructed in stainless steel.

Like all Hannay reels, our stainless steel models are made to last. We manufacture these reels to industrial-duty design and construction standards using fine grade 304 stainless frames, discs, and drums and stainless internals. Because of their exceptional quality, they require only minimal routine maintenance and will not rust, corrode, or break down even in the harshest conditions.

Stainless steel reels come in a standard unpolished mill finish, or you can specify from one of two optional polished finishes that affords the best surface for clean up and sanitary inspection. Optional swivel joints, packings, and materials for internals are available for specific products, pressures, and temperatures.

Hannay's Stainless Steel Finishes

Mill Finish – Standard

Smooth dull "gray" finish as supplied from the mill.

Satin Finish – Optional

Buffed to a grainy light non-reflective finish. Has a brushed look.

Polished Finish – Optional

Buffed to give a bright, reflective finish.

Mounting Hole Sizes

N Series Reels — 7/16" x 7/8" running left to right

Pressed Frame Reels — 7/16" x 7/8" running left to right

Series 1500, 1800, 4000 — 15/32" round holes

Made for the reel world.

In 1933, Clifford Hannay made his first hose reel. Four generations of Hannays have been at it ever since, producing hose and cable reels that make your life in the workplace easier, more productive, and a lot more efficient.

We make Hannay reels for the long run with the best of technology and the finest in craftsmanship. Reels are all we make, so we've learned to do it the right way. From machining a one-piece axle hub assembly, to testing parts before and after they go into our reels.

Not only do we make better reels, we also make more reels than any other manufacturer. Our hose and cable reels solve all kinds of problems in the workplace, and with thousands of standard models, we're sure to have a reel for your application. If you don't find what you're looking for, give us a call and we will design one to meet your needs.

So when you're specifying hose or cable reels, specify Hannay Reels. We're the reel leader.



SSN700 SPRING REWIND REELS

To handle 1/4" through 1/2" I.D. hose.



Optional TR Position
Shown with Optional Polished Finish

For:

- Lubrication
- Potable Water
- Chemical Transfer
- Washdown
- Corrosive Environments

- Standard SSN Series has a narrow frame and compact mounting base.
- Non sparking ratchet assembly.
- Declutching arbor to prevent damage from reverse winding.
- Standard inlet 90° ball bearing swivel joint 1/2" female NPT threads.
- Standard outlet 1/2" female NPT threads.
- Standard Pressures to 3000 psi (207 bar) (available up to 10,000 (690 bar).
- Temperatures from +20° F to +400° F (-7° C to +204° C).
- Consult factory for other pressures & temps.
- 4-way roller assembly.
- Constant Tension is available – consult factory.

Parts Drawing – ISO 171

Model Number	Hose Capacity of Reel				Approx. Weight		Standard Roller Assy	Reel Dimensions***							
	feet				NET	Frt. SHIP Wt.		inches							
	m.							A	B	C	E	F	G	H	X
I.D. (in) I.D. (mm)	1/4" 6	3/8" 10	1/2" 13												
O.D. (in) O.D. (mm)	5/8" 16	3/4" 19	7/8" 22												
SSN716-14-16-8C	–	25	25	52*	70	N204S	10	4	8	17.62	11.25	16.25	9.12	8	
	–	8	8	24	39		254	102	203	448	286	413	232	203	
SSN716-16-17C	–	35	35	55*	71	N204S	10	4	10.5	18.5	11.25	17	9.12	8	
	–	11	11	25	32		254	102	267	470	286	432	232	203	
SSN716-19-20J	–	50	50	64*	85	N204S	10	4	10.5	20.75	11.25	20	10.62	8	
	–	15	15	29	38		254	102	267	527	286	508	270	203	
SSN716-23-24-15.5G	100	75	65	94*	129	N204S	10	4	15.5	23.75	11.25	24	12.62	8	
	30	23	20	43	59		254	102	394	603	286	610	321	203	
SSN716-23-24-15.5J	–	65	65	79*	96	N204S	10	4	15.5	23.75	11.25	24	12.62	8	
	–	20	20	36	44		254	102	394	603	286	610	321	203	
SSN716-25-26-15.5B	–	75	75	90	125	N204S	10	4	15.5	25.25	11.25	26	13.62	8	
	–	23	23	41	57		254	102	394	641	286	660	346	203	
SSN718-25-26-15.5G	–	100	100	96	131	N206S	12	6	15.5	25.25	13.25	26	13.62	10	
	–	30	30	44	59		305	152	394	641	337	660	346	254	

Notes:

1. Specifications subject to change.
2. Reel models and capacities shown are for standard drag applications; for vertical lift applications consult factory.
3. Other sizes, from standard components, available on request.
4. **Finish:** refer to Page 2.
5. **Be sure to check dimensions and weights prior to ordering.**

NOTICE: A Flexible Connector must be used between the inlet pipe and the inlet swivel joint.

* When shipped as a parcel package (via Fed-Ex or UPS Ground).
Net wt. plus carton wt.

*** n/x,n/y indicate mounting holes. See page 2

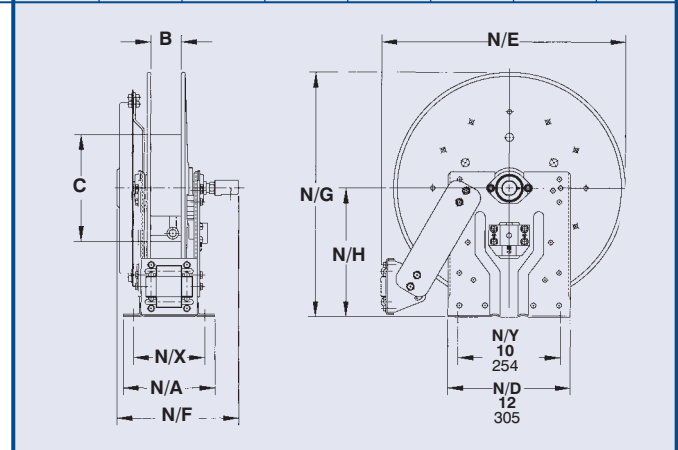

SSN800

SPRING REWIND REELS

To handle 3/4" or 1" I.D. hose.

- Standard N series has a narrow frame and compact mounting base.
- Non sparking ratchet assembly.
- Declutching arbor to prevent damage from reverse winding.
- Standard inlet 90° ball bearing swivel joint 1" female NPT threads.
- Standard outlet 1" female NPT threads.
- Pressures to 1000 psi (69 bar).
- Temperatures from +20° F to +400° F (-7° C to +204° C).
- Consult factory for other pressures & temps.
- 4-way roller assembly
- Constant Tension is available – consult factory.



Shown with Optional Polished Finish

For:

- Dairy
- Caustic Materials
- Air/Water
- Chemical/Food Transfer

Parts Drawing – ISO 173

Model Number	Hose Capacity			Approx. Weight		Standard Roller Assy	Reel Dimensions***							
	feet			lb.	kg.		in.							
	m.						mm							
I.D. (in) I.D. (mm)	3/4" 19	1" 25		NET	SHIP	A	B	C	E	F	G	H	X	
SSN816-19-20J	25 8	15 5	75 34	91* 41	N204S	10 254	4 102	10.5 267	20.75 527	14 356	20 508	10.62 270	8 203	
SSN818-23-24J	50 15	25 8	87 39	100 45	N206S	12 305	6 152	10.5 267	23.75 603	15 381	24 610	12.62 321	10 254	
SSN816-25-26B	60 18	35 11	96 44	131 59	N204S	10 254	4 102	10.5 267	25.25 641	14 356	26 660	13.62 346	8 203	
SSN818-25-26B	70 21	50 15	102 46	137 62	N206S	12 305	6 152	10.5 267	25.25 641	16 406	26 660	13.62 346	10 254	

Notes:

1. Specifications subject to change.
2. Reel models and capacities shown are for standard drag applications; for vertical lift applications consult factory.
3. Other sizes, from standard components, available on request.
4. **Finish:** refer to Page 2.
5. **Be sure to check dimensions and weights prior to ordering.**

NOTICE: A Flexible Connector must be used between the inlet pipe and the inlet swivel joint.

* When shipped as a parcel package (via Fed-Ex or UPS Ground).
 *** n/x, n/y indicate mounting holes. See page 2

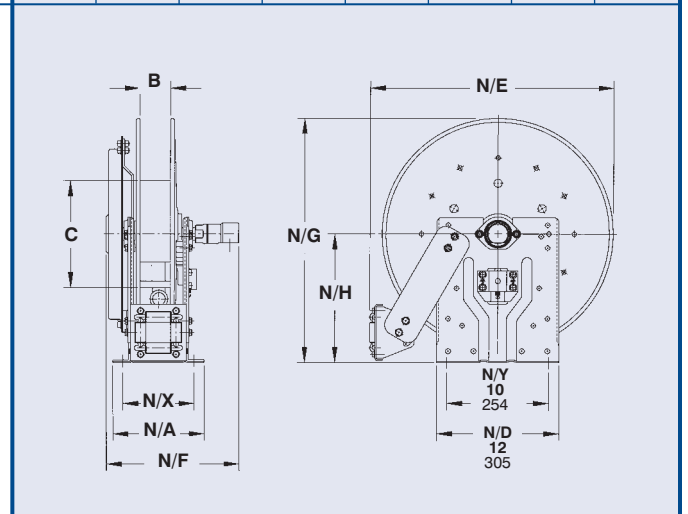

SS800

SPRING REWIND REELS

To handle 3/4" or 1" I.D. hose.



Standard Configuration Shown with Optional Polished Finish

For:

- Dairy
- Caustic Materials

- Air/Water
- Chemical/Food Transfer

- Square tubing frame for heavy-duty applications.
- Non sparking ratchet assembly.
- Declutching arbor to prevent damage from reverse winding.
- Standard inlet 90° ball bearing swivel joint 1" female NPT threads.
- Standard outlet 1" female NPT threads.
- Pressures to 1000 psi (69 bar).
- Temperatures from +20° F to +400° F (-7° C to +204° C).
- Consult factory for other pressures & temps.
- 4-way roller assembly.
- Constant Tension is available – consult factory.

Parts Drawing – ISO 198

Model Number	Hose Capacity			Approx. Weight		Standard Roller Assy	Reel Dimensions***									
	I.D. (in) I.D. (mm)	feet m.		NET	SHIP		A	B	C	D	E	F	G	H	X	Y
		1-9/32" 33	1-9/16" 40													
SS816-25-26B	60 18	35 11	96 44	131 59	R204S	9.25 235	4 102	10.5 267	25 635	26.12 663	13.5 343	25.88 657	13.5 343	4.5 114	22 559	
SS818-25-26B	70 21	50 15	102 46	137 62	R206S	11.25 286	6 152	10.5 267	25 635	26.12 663	15.5 394	25.88 657	13.5 343	6.5 165	22 559	
SS820-25-26-10.5A	85 26	75 23	131 59	166 75	R308S	13.25 337	8 203	10.5 267	25 635	27 686	18.25 464	25.88 657	13.5 343	8.5 216	22 559	
SS820-30-31-10.5A	- -	100 30	137 62	172 78	R308S	13.25 337	8 203	10.5 267	28.5 724	30.5 775	18.25 464	31.38 797	17 432	8.5 216	25.5 648	
SS820-30-31-15.5A	100 30	- -	145 66	180 82	R308S	13.25 337	8 203	15.5 394	28.5 724	30.5 775	18.25 464	31.38 797	17 432	8.5 216	25.5 648	

Notes:

1. Specifications subject to change.
2. Reels models and capacities shown are for standard drag applications; for vertical lift applications consult factory.
3. Other sizes, from standard components, available on request.
4. **Finish:** refer to Page 2.
5. **Be sure to check dimensions and weights prior to ordering.**

NOTICE: A Flexible Connector must be used between the inlet pipe and the inlet swivel joint.

* When shipped as a parcel package (via Fed-Ex or UPS Ground).
 *** x,y indicate mounting holes. See page 2

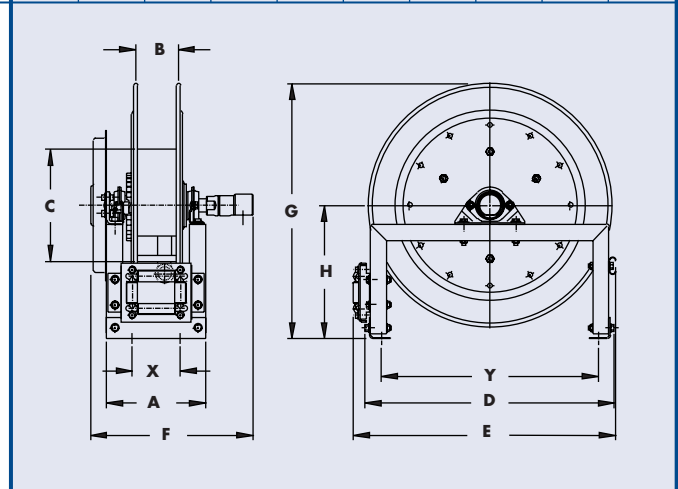

SS1000

COMPACT MANUAL REWIND REELS

To handle single 1/4" or 3/8" I.D. hose.

- Lightweight
- Compact
- Direct crank rewind permanently attached.
- Adjustable cam-lock brake standard.
- Optional pin lock available.
- Standard inlet 90° ball bearing swivel joint 1/2" female NPT threads.
- Standard outlet 3/8" female NPT threads.
- Pressures to 3000 psi (207 bar).
- Temperatures from +20° F to +400° F (-7° C to +204° C).
- Consult factory for other pressures & temps.

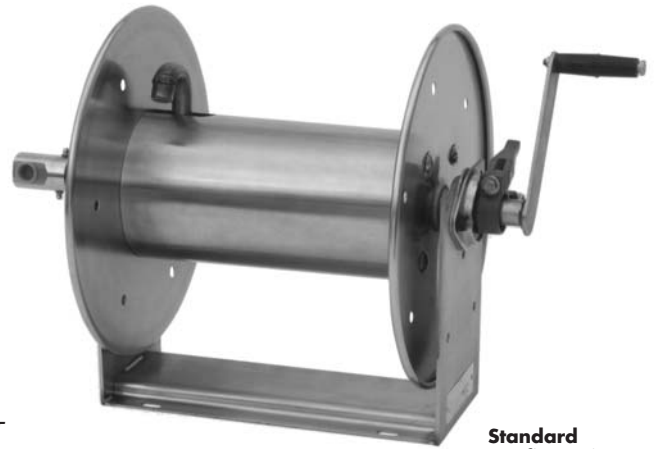

Standard Configuration Shown with Optional Satin Finish

For:

- Pressure Washing
- Spray Operations
- Steam Cleaning
- Washdown
- Air
- Mobile & Permanent Installations

Parts Drawing – ISO 174

Model Number	Hose Capacity of Reel			Approx. Weight		Reel Dimensions***			
	feet m.			Crank Rewind		inches mm.			
	I.D. (in) I.D. (mm)	1/4" 6	3/8" 10	NET	SHIP	A	B	F	X
SS1014-14-16	O.D. (in) O.D. (mm)	5/8" 16	3/4" 19	23 10	30* 14	8.12 206	6 152	19 483	4 102
SS1016-14-16		100 31	75 23	24 11	30* 14	10.12 257	8 203	21 533	6 152
SS1020-14-16		150 46	100 31	25 11	30* 14	14.12 359	12 305	25 635	10 254

Notes:

1. Specifications subject to change.
2. Other sizes, from standard components, available on request.
3. Manual rewind available in RT or LB configurations only.
4. **Finish:** refer to Page 2.

5. Be sure to check dimensions and weights prior to ordering.

NOTICE: A Flexible Connector must be used between the inlet pipe and the inlet swivel joint.

* When shipped as a parcel package (via Fed-Ex or UPS Ground).
 *** x,y indicate mounting holes. See page 2

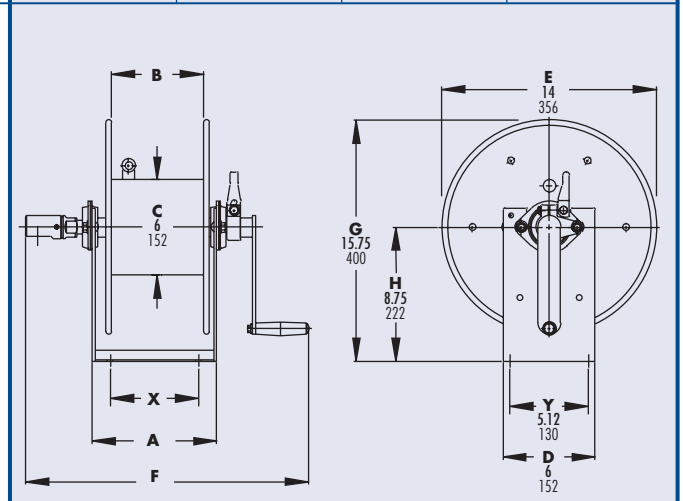

SS1500

MANUAL REWIND REELS

To handle single 1/4" through 5/8" I.D. hose.



Standard Configuration
Shown with Optional
Polished Finish

For:

- Pest Control
- Pressure Washing
- Steam Cleaning

- Lightweight compact reels designed for long lengths of hose.
- Direct crank rewind is permanently attached.
- Cam-lock drag brake, spring actuated pin lock.
- Standard inlet 90° ball bearing swivel joint 1/2" female NPT threads.
- Standard outlet 1/2" female NPT threads.
- Rollers and roller mounting brackets are accessory items. Specify roller position.
- Pressures to 3000 psi (207 bar)
- Temperatures from +20° F to +400° F (-7° C to +204° C).
- Consult factory for other pressures & temps.
- Consult factory for power version.

Parts Drawing – ISO 175

Model Number	Hose Capacity of Reel					Approx. Weight		Reel Dimensions***				
	feet					Crank Rewind		inches				
	m.					lb.		mm.				
I.D. (in)	1/4"	3/8"	1/2"	5/8"	NET	SHIP	A	B	E	F	X	
I.D. (mm)	6	10	13	16								
O.D. (in)	5/8"	3/4"	7/8"	1"								
O.D. (mm)	16	19	22	25								
SS1514-17-18	175	125	75	50	27	50*	11	6	16.5	19	9.5	
	53	38	23	15	12	23	279	152	419	483	241	
SS1520-17-18	350	275	175	125	29	50*	17	12	16.5	25	15.5	
	107	84	53	38	13	23	432	305	419	635	394	
SS1526-17-18	500	400	300	200	31	50*	23	18	16.5	31	21.5	
	152	122	91	61	14	23	584	457	419	787	546	
SS1530-17-18	–	500	375	275	33	50*	27	22	16.5	35	25.5	
	–	152	114	84	15	23	686	559	419	889	648	
SS1536-17-18	–	–	475	350	35	50*	33	28	16.5	41	31.5	
	–	–	145	107	16	23	838	711	419	1041	800	

Notes:

1. Specifications subject to change.
2. Upon request, reels can be supplied with drum lengths other than shown.
3. Dimension "F" is the overall length of standard model reels.
4. Manual rewind available in RT or LB configurations only.
5. **Finish:** refer to Page 2.
6. **Be sure to check dimensions and weights prior to ordering.**

NOTICE: A Flexible Connector must be used between the inlet pipe and the inlet swivel joint.

* When shipped as a parcel package (via Fed-Ex or UPS Ground).

*** x,y indicate mounting holes. See page 2

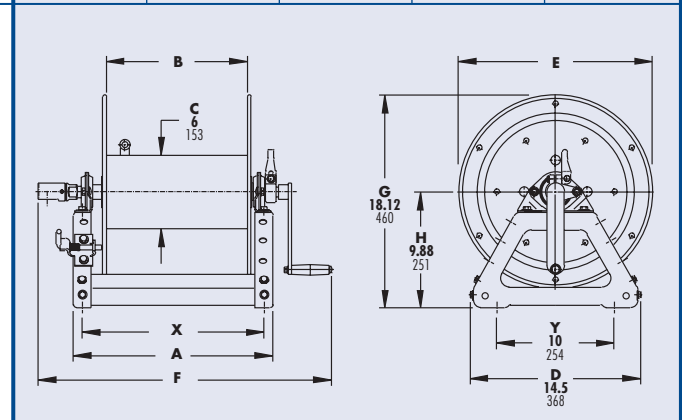

SS1800

MANUAL REWIND REELS

To handle single 5/8" or 3/4" I.D. hose.

- Lightweight compact reels designed for long lengths of hose.
- Direct crank rewind is permanently attached.
- Cam-lock brake, spring actuated pin lock.
- Standard inlet 90° ball bearing swivel joint 1" female NPT threads.
- Standard outlet 3/4" female NPT threads.
- Rollers and roller mounting brackets are accessory items. Specify roller position.
- Pressures to 1000 psi (69 bar).
- Temperatures from +20° F to +400° F (-7° C to +204° C).
- Consult factory for other pressures & temps.



For:

- Pest Control
- Pressure Washing
- Steam Cleaning
- Washdown

Parts Drawing – ISO 176

Model Number	Hose Capacity of Reel			Approx. Weight		Reel Dimensions***				
	feet			Crank Rewind		inches				
	m.			lb.		mm.				
I.D. (in)	5/8"	3/4"	NET	SHIP	A	B	E	F	X	
I.D. (mm)	19	19								
O.D. (in)	1"	1-9/32"								
O.D. (mm)	25	40								
SS1816-17-18	75 23	50 15	28 13	50* 23	13 330	8 203	16.5 419	23.38 594	11.5 292	
SS1822-17-18	150 46	100 30	30 14	50* 23	19 483	14 356	16.5 419	29.38 746	17.5 445	
SS1826-17-18	200 61	150 46	32 15	50* 23	23 584	18 457	16.5 419	33.38 848	21.5 546	
SS1830-17-18	275 84	175 53	33 15	50* 23	27 686	22 559	16.5 419	37.38 950	25.5 648	
SS1836-17-18	350 107	225 69	36 16	50* 23	33 838	28 711	16.5 419	43.38 1102	31.5 800	

Notes:

1. Specifications subject to change.
2. Upon request, reels can be supplied with drum lengths other than shown.
3. Dimension "F" is the overall length of standard model reels.
4. Manual rewind available in RT or LB configurations only.
5. **Finish:** refer to Page 2.

6. Be sure to check dimensions and weights prior to ordering.

NOTICE: A Flexible Connector must be used between the inlet pipe and the inlet swivel joint.

* When shipped as a parcel package (via Fed-Ex or UPS Ground).

*** x,y indicate mounting holes. See page 2

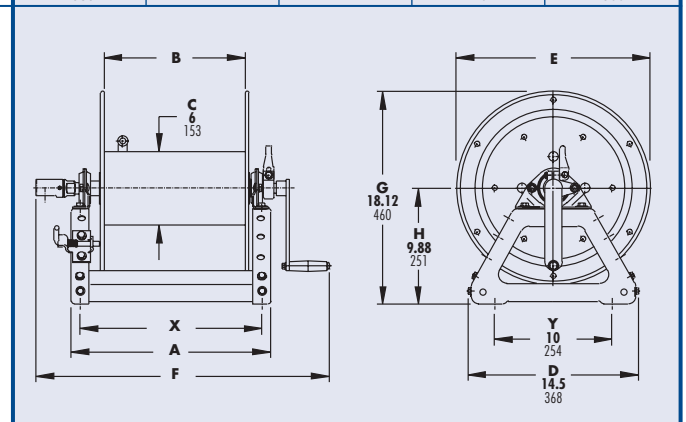

SS3000

MANUAL REWIND REELS

To handle 3/4" or 1" I.D. hose.



Standard Mill Finish Shown

For:

- Marine/Corrosive Environments
- Fire Protection
- Washdown
- Chemical/Food Transfer

- Economical manual rewind reels for long lengths of hose.
- Choose disc rewind or removable direct crank rewind.
- Supplied with spring-actuated pin lock.
- Standard inlet 90° ball bearing swivel joint 1" female NPT threads.
- Standard outlet 1" female NPT thread.
- Rollers and roller mounting brackets are accessory items. Specify roller position.
- Pressures to 1000 psi (69 bar)
- Temperatures from +20° F to +400° F (-7° C to +204° C).
- Consult factory for other pressures & temps.
- Consult factory for power reels for 1" hose.

Parts Drawing – ISO 177

Model Number	Hose Capacity of Reel				Approx. Weight Crank Rewind		Reel Dimensions***			
	feet m.				lb. kg.		inches mm.			
	Round Hose		Collapsible Hose		NET	SHIP	A	B	F	X
I.D. (in)	3/4"	1"	1"							
I.D. (mm)	19	25	25							
O.D. (in)	1-9/32"	1-9/16"	1/2"x1-3/4"							
O.D. (mm)	33	40	13 x 44							
SS3016-25-26	100 30	50 15	200 61	85 39	120 54	13 330	7.5 191	23.75 603	7.75 197	
SS3020-25-26	150 46	100 30	300 91	94 43	129 59	17 432	11.5 292	27.75 705	9 229	
SS3024-25-26	250 76	150 46	400 122	103 47	138 63	21 533	15.5 394	31.75 806	13 330	
SS3028-25-26	300 91	200 61	550 168	113 51	155 70	25.5 648	20 508	36.25 921	17.5 445	

Notes:

1. Specifications subject to change.
2. Upon request, reels can be supplied with drum lengths other than shown and with disc sizes in other diameters.
3. **Power rewind NOT available on these models.**
4. Dimension "F" is the overall length of standard model reels. Crank rewind models, 3-1/2" clearance required to remove crank.
5. Subtract 5" from 'F' dimension for disc rewind models.
6. **Finish:** Refer to Page 2.
7. **Be sure to check dimensions and weights prior to ordering.**

NOTICE: A Flexible Connector must be used between the inlet pipe and the inlet swivel joint.

*** x,y indicate mounting holes. See page 2

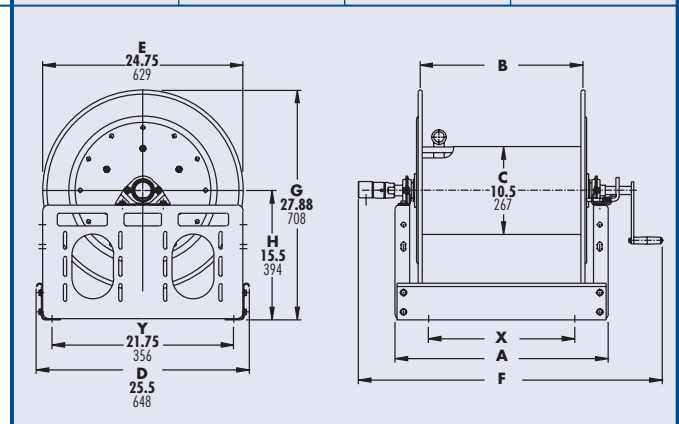

SS4000

MANUAL REWIND REELS

To handle single 3/4" or 1" I.D. hose.

- Lightweight compact reels designed for long lengths of hose.
- Direct crank rewind is removable.
- Cam-lock brake, spring actuated pin lock.
- Standard inlet 90° ball bearing swivel joint 1" female NPT threads.
- Standard outlet 1" female NPT threads.
- Rollers and roller mounting brackets are accessory items. Specify roller position.
- Pressures to 1000 psi (69 bar).
- Temperatures from +20° F to +400° F (-7° C to +204° C).
- Consult factory for other pressures & temps.



For:

- Food Processing
- Bottling Plants
- Fire Protection
- Water Supply
- Chemical Transfer

Parts Drawing – ISO 178

Model Number	Hose Capacity of Reel <u>feet</u> m.			Approx. Weight Crank Rewind <u>lb.</u> kg.		Reel Dimensions*** <u>inches</u> mm.				
	I.D. (in) I.D. (mm)	3/4" 19	1" 25	NET	SHIP	A	B	E	F	X
	O.D. (in) O.D. (mm)	1-9/32" 33	1-9/16" 40							
SS4018-17-18		50 15	35 11	36 16	50* 23	15 381	10 254	16.5 419	27 686	13.5 343
SS4024-17-18		100 30	50 15	46 21	56* 25	21 533	16 406	16.5 419	33 838	19.5 495
SS4030-17-18		150 46	75 23	57 26	62* 28	27 686	22 559	16.5 419	39 991	25.5 648
SS4038-17-18		200 61	100 30	70 32	112 51	35 889	30 762	16.5 419	47 1194	33.5 851

Notes:

1. Specifications subject to change.
2. Upon request, reels can be supplied with drum lengths other than shown.
3. Dimension "F" is the overall length of standard model reels. Crank rewind reels require 3-1/2" clearance to remove or install crank handle.
4. **Finish:** refer to Page 2.
5. **Be sure to check dimensions and weights prior to ordering.**

NOTICE: A Flexible Connector must be used between the inlet pipe and the inlet swivel joint.

* When shipped as a parcel package (via Fed-Ex or UPS Ground).
 *** x,y indicate mounting holes. See page 2

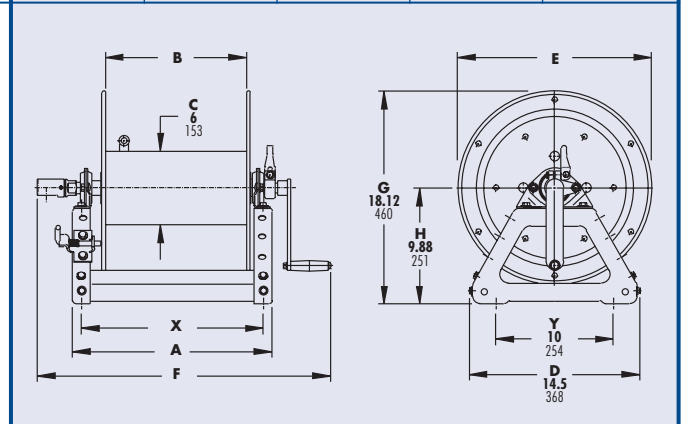



HANNAY STAINLESS STEEL FUEL REELS

Hannay Reel's beginnings started with the Fuel Delivery industry in 1933.

Hannay now offers Stainless Steel model reels for home delivery of Fuel Oil and L.P. gas, used by OEMs worldwide.

Aviation fueling OEMs are now also using Hannay Stainless Steel reels for lasting quality and efficiency under all weather conditions and atmospheres.

Log on to www.hannay.com and see the Hannay Fuel Catalogs or call the Hannay Inside Sales group today for more information.



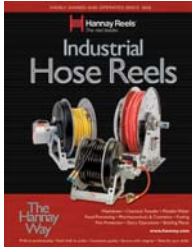

Hose Reels

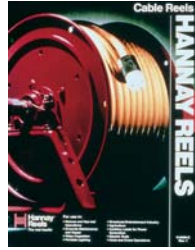

Cable Reels

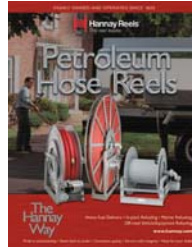

Petroleum Hose Reels



Welding Reels

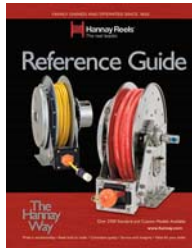

Reference Guide



Pressure Wash Reels



Audio/Video Reels



Ordering & Accessory Guide



Family owned and operated since 1933, Hannay Reels is a leader in both OEM and aftermarket applications. Hannay offers thousands of standard hose reel and cable reel models, as well as unmatched custom capabilities. We can easily and affordably customize a reel to meet your exact specifications – built to last, delivered fast. Additional catalogs are available through your local Hannay Reels dealer or online at www.hannay.com.



553 State Route 143 • Westerlo, New York 12193-0159
Toll Free Phone: 1-877-GO-REELS • Toll Free Fax: 1-800-REELING

E-mail: reels@hannay.com

Intl. Phone: 1-518-797-3791 • Intl. Fax: 1-518-797-3259

www.hannay.com



MADE IN U.S.A.