

FAMILY OWNED AND OPERATED SINCE 1933



# Pressure Washing and Spray Hose Reels



The  
Hannay  
Way

Pressure Washing • Steam Cleaning • Spray Operations  
Washdown • Maintenance • Auto Washing • Processing Plants  
Grounds Maintenance • Pest Control • Vehicle Maintenance  
Lawn Care Service • Tree Spraying • Agriculture

[www.hannay.com](http://www.hannay.com)

Pride in workmanship • Reels built to order • Consistent quality • Service with integrity • Value for your dollar

# PW

## PRESSURE WASH REEL

**Specially Designed for Pressure Wash Professionals**

- Hannay PW Series quickly mount.
- Pressure rating up to 4000 psi.

### Standard Features

- 12 and 16 gauge steel.
- Black powder coat finish.
- Adjustable split bearing brake assembly.
- Dual side bearing support.
- Flow rate of over 12 gpm @ 15 fps.
- Captive (4 sided) hose guide roller assembly.
- Universal mounting pattern (2.75" x 5") optional mounting kits.

### Optional Mounting Kits & Accessories

**PWK-400** – For wall mounting with the ability to pivot the reel. Includes pivoting platform, knob, and mounting hardware. (Mounting hole pattern: 2.75" x 2.75").

**PWK-300** – For mounting to 1" round tubing.

**PWK-301** – For mounting to 1-1/4" round tubing.

**PWK-302** – For mounting to 1" square tubing.

**PWK-303** – For mounting to 1-1/4" square tubing.

**PWK-200** – For rigid (non-pivoting) wall mounting.

**PWK-150** – For base (floor) mounting with the ability to pivot the reel. Includes pivoting platform, knob, and mounting hardware.

**PWK-400/PWK-300 Combination Kit** – For mounting to 1" round tubing providing the ability to still pivot the reel.

**PWK-400/PWK-301 Combination Kit** – For mounting to 1-1/4" round tubing providing the ability to still pivot the reel.



with optional PWK-400/300 combo kit — horizontal installation



with optional PWK-400 kit



with optional PWK-400/300 combo kit — vertical installation



with optional PWK-300 kit

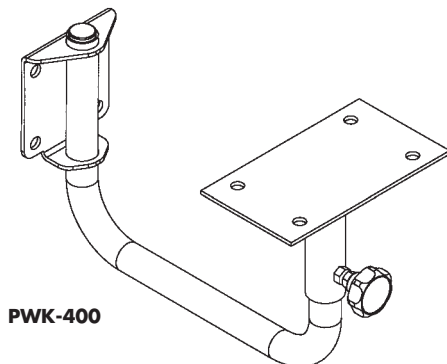

PWK-400

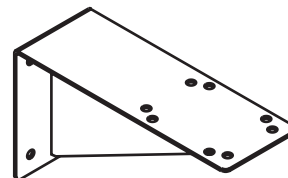

PWK-200

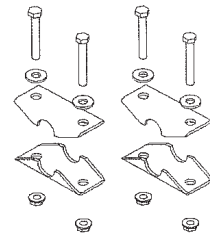

PWK-300



Shown with optional PWK-200 mounting kit

**For:**

- Pressure Washing
- Steam Cleaning
- Spray Operations
- Washdown

# PW-2

## MANUAL REWIND REEL

To handle single 3/8" I.D. hose.

- Lightweight, compact and versatile, the PW Series designed for mobile and portable pressure wash equipment.
- Permanent direct crank rewind .
- Adjustable split bearing brake assembly.
- Standard inlet full-flow swivel joint with 1/2" NPT fitting.
- Standard outlet 3/8" female NPT fitting
- Other sizes and/or threads can be furnished and must be specified.
- Pressures up to 4000 psi (276 bar).
- Product temperatures from +20°F to +400°F (-7°C to + 204°C).
- Consult factory for other temperatures.
- Specify mounting position when ordering mounting kits.
- Black powder coat finish.

### Parts Drawing – ISO 193

Model Number	Hose Capacity of Reel feet m.		Approx. Weight Crank Rewind lb. kg.		Reel Dimensions*** inches mm.									
	I.D. (in) I.D. (mm)	3/8" 10	NET	SHIP	A	B	C	D	E	F	G	H	X	Y
PW-2	O.D. (in) O.D. (mm)	3/4" 19			26 12	32* 15	9 229	6 152	6 152	4 102	16.75 425	17 432	18.25 464	10 254

**Notes:**

1. Specifications subject to change.
2. **Finish:** refer to Page 7.
3. **Be sure to check dimensions and weights prior to ordering.**

**NOTICE:** A Flexible Connector must be used between the inlet pipe and the inlet swivel joint.

\* When shipped as a parcel package (via FedEx or UPS Ground).  
\*\*\* x,y indicate mounting holes.

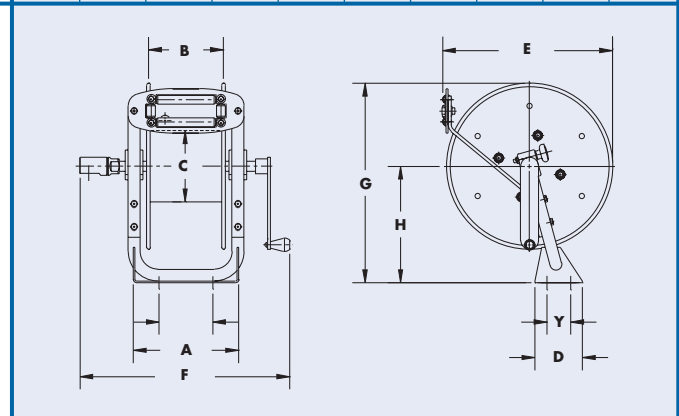

# N700

## SPRING REWIND REELS

To handle 1/4" through 1/2" I.D. hose.

- Standard N Series has a narrow frame and compact mounting base.
- Non sparking ratchet assembly.
- Declutching arbor to prevent damage from reverse winding.
- Standard inlet 90° balanced pressure swivel joint 1/2" female NPT threads.
- Standard outlet 1/2" female NPT threads.
- Standard Pressures to 3000 psi (207 bar) (available up to 10,000 psi 690 bar).
- Temperatures from -60° F to +250° F (-51° C to +121° C).
- Consult factory for other pressures & temps.
- 4-way roller assembly.
- Constant Tension is available – consult factory.



Shown with  
Optional TR  
Roller Position

For:

- Air/Water
- Washdown
- Air Tools

### Parts Drawing – ISO 79

Model Number	Hose Capacity of Reel feet m.				Approx. Weight lb. kg.		Standard Roller Assy	Reel Dimensions*** inches mm.							
	I.D. (in) I.D. (mm)	1/4" 6	3/8" 10	1/2" 13	NET	Frt. SHIP Wt.		A	B	C	E	F	G	H	X
	O.D. (in) O.D. (mm)	5/8" 16	3/4" 19	7/8" 22											
N716-14-16-8C	–	25	25	–	52*	70	N204	10	4	8	17.62	11.25	16.25	9.12	8
	–	8	8	–	24	39		254	102	203	448	286	413	232	203
N716-16-17C	–	35	35	–	55*	71	N204	10	4	10.5	18.5	11.25	17	9.12	8
	–	11	11	–	25	32		254	102	267	470	286	432	232	203
N716-19-20J	–	50	50	–	64*	85	N204	10	4	10.5	20.75	11.25	20	10.62	8
	–	15	15	–	29	38		254	102	267	527	286	508	270	203
N716-23-24-15.5G	100	75	65	30	94*	129	N204	10	4	15.5	23.75	11.25	24	12.62	8
	–	23	20	–	43	59		254	102	394	603	286	610	321	203
N716-23-24-15.5J	–	65	65	–	79*	96	N204	10	4	15.5	23.75	11.25	24	12.62	8
	–	20	20	–	36	44		254	102	394	603	286	610	321	203
N716-25-26-15.5B	–	75	75	–	90	125	N204	10	4	15.5	25.25	11.25	26	13.62	8
	–	23	23	–	41	57		254	102	394	641	286	660	346	203
N718-25-26-15.5G	–	100	100	–	96	131	N206	12	6	15.5	25.25	13.25	26	13.62	10
	–	30	30	–	44	59		305	152	394	641	337	660	346	254

**Notes:**

1. Specifications subject to change.
2. Reel models and capacities shown are for standard drag applications; for vertical lift applications consult factory.
3. Other sizes, from standard components, available on request.
4. **Finish:** refer to Page 7.
5. **Be sure to check dimensions and weights prior to ordering.**

**NOTICE:** A Flexible Connector must be used between the inlet pipe and the inlet swivel joint.

- \* When shipped as a parcel package (via FedEx or UPS Ground). Net wt. plus carton wt.
- \*\*\* x,y indicate mounting holes.

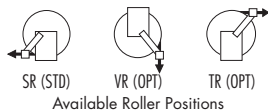
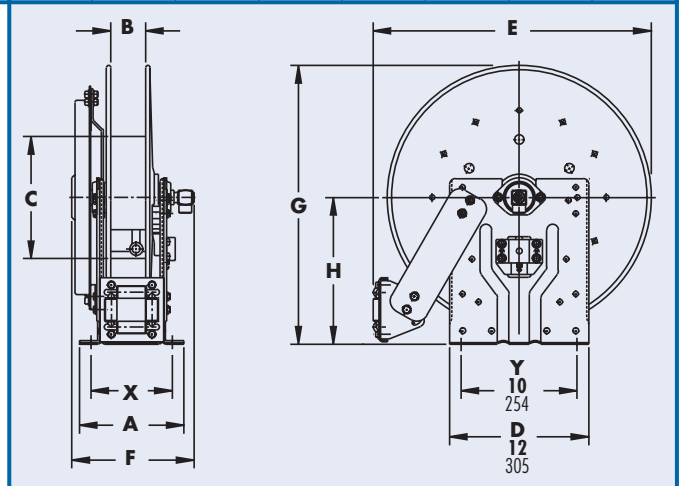

Available Roller Positions

# 1000

## COMPACT MANUAL REWIND REELS

To handle single 1/4" or 3/8" I.D. hose.



Standard Configuration & Stainless Construction Shown

- Lightweight
- Compact
- Direct crank rewind permanently attached.
- Adjustable cam-lock brake standard.
- Optional pin lock available.
- Standard inlet 90° ball bearing swivel joint 1/2" female NPT threads.
- Standard outlet 3/8" female NPT threads.
- Pressures to 3000 psi (207 bar).
- Temperatures from +20° F to +400° F (-7° C to +204° C).
- Consult factory for other pressures & temps.

For:

- Pressure Washing
- Washdown
- Spray Operations
- Air

### Parts Drawing – ISO 165

Model Number	Hose Capacity of Reel			Approx. Weight		Reel Dimensions***			
	I.D. (in) I.D. (mm)	feet m.		lb. kg.		inches mm.			
	1/4" 6	3/8" 10		NET	SHIP	A	B	F	X
	5/8" 16	3/4" 19							
1014-14-16	100 31	75 23		23 10	30* 14	8.12 206	6 152	19 483	4 102
1016-14-16	150 46	100 31		24 11	30* 14	10.12 257	8 203	21 533	6 152
1020-14-16	250 76	175 53		25 11	30* 14	14.12 359	12 305	25 635	10 254

**Notes:**

1. Specifications subject to change.
2. Other sizes, from standard components, available on request.
3. **Finish:** refer to Page 7.

**4. Be sure to check dimensions and weights prior to ordering.**

**NOTICE:** A Flexible Connector must be used between the inlet pipe and the inlet swivel joint.

\* When shipped as a parcel package (via FedEx or UPS Ground).  
 \*\*\* x,y indicate mounting holes.

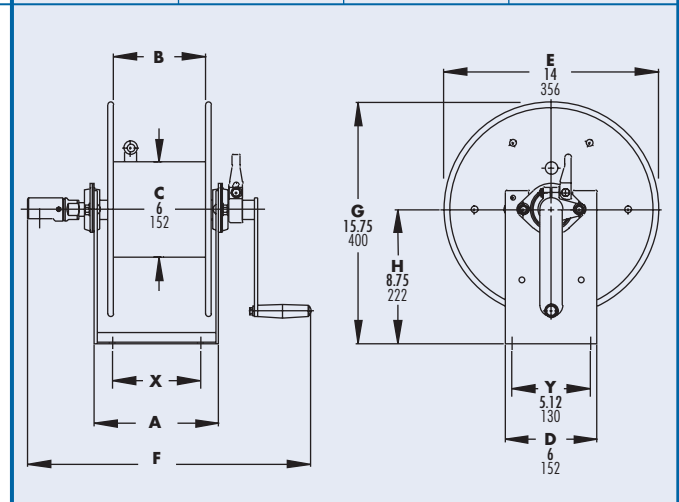

# MANUAL OR POWER REWIND REELS

- Lightweight compact reels designed for long lengths of hose in manual and power rewind.
- Direct crank rewind is permanently attached.
- Chain and sprocket drive powered by electric, hydraulic, or compressed air motor.
- Direct crank rewind, cam-lock drag brake, spring actuated pin lock.
- Optional Rollers: Specify roller position when ordering.

## Optional External Mounting Brackets



Part no. 9906.0025.  
Add 2-1/2" to the X  
dimensions shown in  
the chart.

# 1500

## To handle single 1/4" through 5/8" I.D. hose.

- Standard inlet 90° ball bearing swivel joint 1/2" female NPT threads.
- Standard outlet 1/2" female NPT threads.
- Pressures to 3000 psi (207 bar)
- Temperatures from +20° F to +400° F (-7° C to +204° C).
- Consult factory for other pressures & temps.



For:

- Lawn Care
- Pest Control
- Pressure Washing
- Agriculture
- Steam Cleaning

Electric Rewind  
Standard Configuration Shown

# 1800

## To handle single 5/8" or 3/4" I.D. hose.

- Standard inlet 90° ball bearing swivel joint 1" female NPT threads.
- Standard outlet 3/4" female NPT threads.
- Pressures to 1000 psi (69 bar).
- Temperatures from -40° F to +250° F (-40° C to +121° C).
- Consult factory for other pressures & temps.

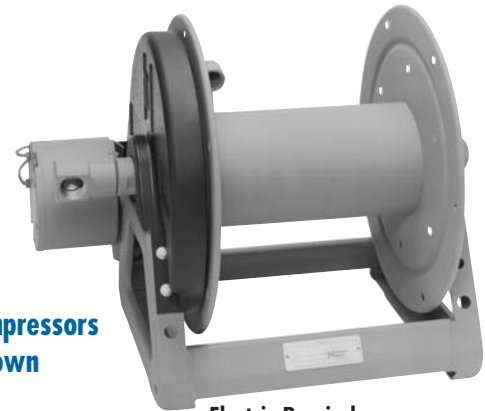

For:

- Air Compressors
- Washdown

Electric Rewind  
Standard Configuration Shown

# 4000

## To handle single 3/4" or 1" I.D. hose.

- Direct crank rewind is removable.
- Standard inlet 90° ball bearing swivel joint 1" female NPT threads.
- Standard outlet 1" female NPT threads.
- Pressures to 1000 psi (69 bar).
- Temperatures from -60° F to +250° F (-51° C to +121° C).
- Consult factory for other pressures & temps.
- Comet brake is standard on power rewind reels.

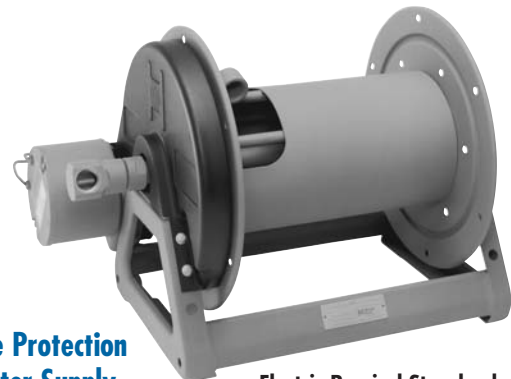

For:

- Fire Protection
- Water Supply
- Chemical Transfer

Electric Rewind Standard  
Configuration Shown

**Parts Drawing – Series 1500 – ISO 90 (power), ISO 179 (manual); Series 1800 – ISO 136; Series 4000 – ISO 68**

Model Number	Hose Capacity of Reel feet m.							Approx. Weight Crank Rewind <sup>3</sup> lb. kg.		Reel Dimensions*** inches mm.						
	I.D. (in) I.D. (mm)	1/4" 6	3/8" 10	1/2" 13	5/8" 16	3/4" 19	1" 25	NET	SHIP	A	B	E CRANK	E POWER	F CRANK	F POWER	X
	O.D. (in) O.D. (mm)	5/8" 16	3/4" 19	7/8" 22	1" 25	1-9/32" 33	1-9/16" 40									
1514-17-18		175 53	125 38	75 23	50 15	– –	– –	27 12	50* 23	11 279	6 152	16.5 419	19 483	19 483	16.5 419	9.5 241
1520-17-18		350 107	275 84	175 53	125 38	– –	– –	29 13	50* 23	17 432	12 305	16.5 419	19 483	25 635	22.5 572	15.5 394
1526-17-18		500 152	400 122	300 91	200 61	– –	– –	31 14	50* 23	23 584	18 457	16.5 419	19 483	31 787	28.5 724	21.5 546
1530-17-18		– –	500 152	375 114	275 84	– –	– –	33 15	50* 23	27 686	22 559	16.5 419	19 483	35 889	32.5 826	25.5 648
1536-17-18		– –	– –	475 145	350 107	– –	– –	35 16	50* 23	33 838	28 711	16.5 419	19 483	41 1041	38.5 978	31.5 800
1816-17-18		– –	– –	– –	75 23	50 15	– –	28 13	50* 23	13 330	8 203	16.5 419	19 483	23.38 594	18.5 470	11.5 292
1822-17-18		– –	– –	– –	150 46	100 30	– –	30 14	50* 23	19 483	14 356	16.5 419	19 483	29.38 746	24.5 622	17.5 445
1826-17-18		– –	– –	– –	200 61	125 38	– –	32 15	50* 23	23 584	18 457	16.5 419	19 483	33.38 848	28.5 724	21.5 546
1830-17-18		– –	– –	– –	275 84	150 46	– –	33 15	50* 23	27 686	22 559	16.5 419	19 483	37.38 950	32.5 826	25.5 648
1836-17-18		– –	– –	– –	350 107	200 61	– –	36 16	50* 23	33 838	28 711	16.5 419	19 483	43.38 1102	38.5 978	31.5 800
4018-17-18		– –	– –	– –	50 15	35 11	– –	36 16	50* 23	15 381	10 254	16.5 419	19 483	27 686	20.5 521	13.5 343
4024-17-18		– –	– –	– –	– –	100 30	50 15	46 21	56* 25	21 533	16 406	16.5 419	19 483	33 838	26.5 673	19.5 495
4030-17-18		– –	– –	– –	150 46	75 23	– –	57 26	62* 28	27 686	22 559	16.5 419	19 483	39 991	32.5 826	25.5 648
4038-17-18		– –	– –	– –	200 61	100 30	– –	70 32	112 51	35 889	30 762	16.5 419	19 483	47 1194	40.5 1029	33.5 851

**Notes:**

- Specifications subject to change.
- Upon request, reels can be supplied with drum lengths other than shown.
- Weights shown in chart are for crank rewind models. ADD these amounts for power rewind models:  

	<b>Net (lbs.)</b>	<b>Ship (lbs.)</b>	<b>Net (kg.)</b>	<b>Ship (kg.)</b>
Electric	<b>18</b>	<b>18</b>	8.2	8.2
Hydraulic	<b>15</b>	<b>15</b>	6.8	6.8
Air	<b>15</b>	<b>15</b>	6.8	6.8
- Series 1500 and 1800 - dimension "F" is the overall length of standard model reels.  
Series 4000 - crank rewind reels require 3-1/2" clearance to remove or install crank handle.
- When ordering power rewind models, prefix model number with:  
A = Air Rewind    E = Electric Rewind    HD = Hydraulic Rewind  
(Air rewind reels are supplied with control valve and hose; 12v and 24v DC rewind reels are supplied with switch and solenoid; 115v AC rewind reels are not supplied with control valve.)
- Series 1500 and 1800 - manual rewind available in RT or LB configurations only.
- Finish:** refer to Page 7.
- 8. Be sure to check dimensions and weights prior to ordering.**
- Some roller options may prohibit the use of our molded chain guard.

**NOTICE:** A Flexible Connector must be used between the inlet pipe and the inlet swivel joint.

\* When shipped as a parcel package (via FedEx or UPS Ground).  
\*\*\* x,y indicate mounting holes.

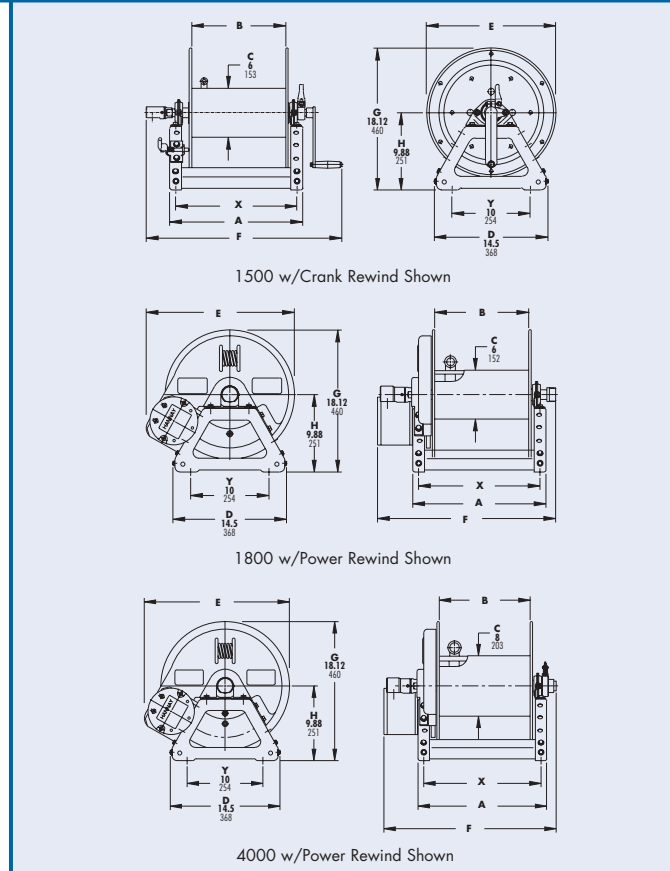

# 6000

## MANUAL OR POWER REWIND REELS

To handle single 1/2" through 1" I.D. hose.

- Heavy-duty reel for longer lengths of hose.
- Choose Gear-driven crank rewind or chain and sprocket drive powered by an electric, hydraulic or compressed air motor.
- Crank rewind reels supplied with pinion brake, power rewind reels with a comet brake.
- Standard inlet a 90° ball bearing swivel joint 1" female NPT threads.
- Standard outlet 1" female NPT threads.
- Standard inlet, outlet riser and hub assembly are steel. Optional bronze or aluminum swivel joint and stainless steel hub assembly and riser, are available.
- Optional Rollers may be purchased.
- Pressures to 1000 psi (69 bar).
- Temperatures from -60° F to +250° F (-51° C to +121° C).
- Consult factory for other pressures & temps.

### Paint Notice

To meet the requirements and performance of vehicle and OEM apparatus paints we recommend our reels be painted with the same or equal paint as used on the specific apparatus the reel is being mounted on.

Hannay Reels will supply any model or custom reel or part with an automotive primer or rust preventative oil finish upon request, allowing application of final coating at your facility. Or at additional cost Hannay can prime/pre-paint all material before final assembly.

In today's regulatory environment this would be the most cost-effective way to meet your finishing standards.

Consult factory for other optional finishes

Standard finish is oven cured enamel. High performance finishes for demanding and corrosive environments are available at an additional cost. Consult factory for specific requirements.

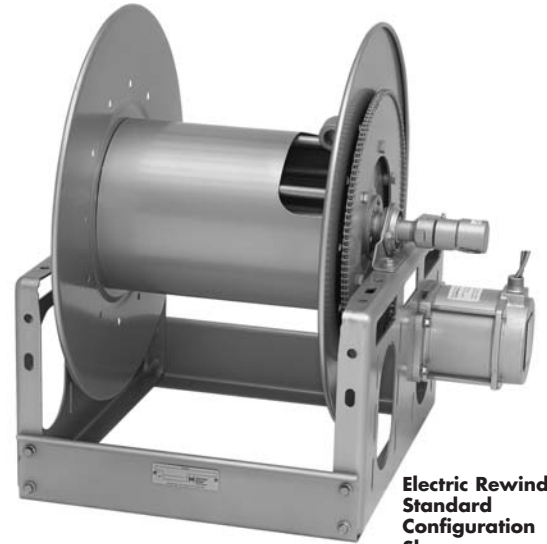

Electric Rewind Standard Configuration Shown

For:

- Spray Operations
- Fire Protection
- Water Blasting\*
- Sewer Cleaning\*

\*Heavy-duty construction required. Consult factory.



Shown with optional Assembly C Roller Top Wind

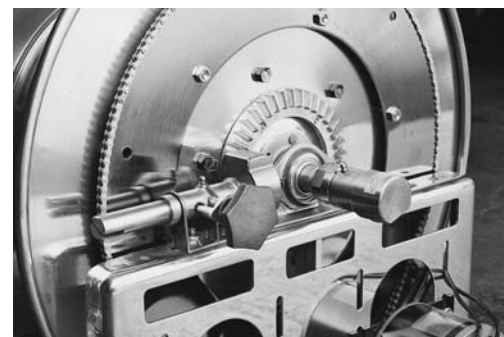

### Optional Auxiliary Rewind

Ring and pinion shaft rewind unit with removable crank handle

# 6000

## Parts Drawing – ISO 84

Model Number	Hose Capacity of Reel				Approx. Weight Crank Rewind <sup>3</sup>		Reel Dimensions****									
	feet m.				lb. kg.		inches mm.									
	I.D. (in) I.D. (mm)	1/2" 13	3/4" 19	1" 25	NET	SHIP	A	B	D	E	F CRANK	F POWER	G	H	X	Y
O.D. (in) O.D. (mm)	7/8" 22	1-9/32" 33	1-9/16" 40													
6024-19-21	235 72	125 38	60 18	85 39	127 58	21 533	15.5 394	20.5 521	18.75 476	25.38 645	28.5 724	21.5 546	12.12 308	13 330	16.75 425	
6032-19-21	350 107	200 61	100 30	102 46	144 65	29.5 749	24 610	20.5 521	18.75 476	33.88 861	37 940	21.5 546	12.12 308	21.5 546	16.75 425	
6024-23-24	450 137	185 56	100 30	92 42	134 61	21 533	15.5 394	20.5 521	22.75 578	25.38 645	28.5 724	23.5 597	12.12 308	13 330	16.75 425	
6030-23-24	– –	250 76	150 46	105 48	147 67	27.5 699	22 559	20.5 521	22.75 578	31.88 810	35 889	23.5 597	12.12 308	19.5 495	16.75 425	
6038-23-24	– –	350 107	200 61	120 54	162 73	35 889	29.5 749	20.5 521	22.75 578	39.38 1000	42.5 1080	23.5 597	12.12 308	27.5 699	16.75 425	
6016-25-26	285 87	100 30	60 18	88 40	130 59	13 330	7.5 191	25.5 648	24.75 629	17.38 441	20.5 521	27.88 708	15.5 394	7.75 197	21.75 552	
6022-25-26	500 152	200 61	100 30	100 45	142 64	19 483	13.5 343	25.5 648	24.75 629	23.38 594	26.5 673	27.88 708	15.5 394	11 279	21.75 552	
6028-25-26	– –	300 91	200 61	113 51	155 70	25.5 648	20 508	25.5 648	24.75 629	29.88 759	33 838	27.88 708	15.5 394	17.5 445	21.75 552	
6018-30-31	450 137	235 72	135 41	101 46	151 68	15 381	9.5 241	25.5 648	28.75 730	19.38 492	22.5 572	29.88 759	15.5 394	7 178	21.75 552	
6024-30-31	– –	400 122	200 61	113 51	163 74	21 533	15.5 394	25.5 648	28.75 730	25.38 645	28.5 724	29.88 759	15.5 394	13 330	21.75 552	
6028-30-31	– –	500 152	265 81	121 55	171 78	25.5 648	20 508	25.5 648	28.75 730	29.88 759	33 838	29.88 759	15.5 394	17.5 445	21.75 552	
† 6030-30-31	– –	550 168	300 91	125 57	175 79	27.5 699	22 559	25.5 648	28.75 730	31.88 810	35 889	29.88 759	15.5 394	19.5 495	21.75 552	
† 6028-33-34	– –	600 183	350 107	129 59	179 81	25 635	20 508	31.5 800	31.75 806	29.62 752	32.75 832	33.62 854	17.75 451	17.5 445	27.75 705	

**Notes:**

Specifications subject to change.

1. Upon request, reels can be supplied with drum lengths other than shown and with disc sizes in other diameters.
2. Dimensions shown for reels up to and including 30-31 disc size reflect pressed frames. All others are rollformed channel frames.
3. Weights shown in chart are for crank rewind models. ADD these amounts for power rewind models:

	Net (lbs.)	Ship (lbs.)	Net (kg.)	Ship (kg.)
Electric 1/2 HP	40	40	18.1	18.1
Hydraulic	20	20	9.1	9.1
Air	20	20	9.1	9.1

4. When ordering power rewind models, prefix model number with:  
A = Air Rewind EP = Electric Rewind (1/2 hp) HD = Hydraulic Rewind  
(Air rewind reels are supplied with control valve and hose; 12v and 24v DC rewind reels are supplied with switch and solenoid; 115v AC rewind reels are not supplied with switch but can be ordered separately; hydraulic rewind reels are not supplied with control valve.)

5. **Finish:** refer to Page 7.

6. **Be sure to check dimensions and weights prior to ordering.**

**NOTICE:** A Flexible Connector must be used between the inlet pipe and the inlet swivel joint.

\*\*\* x,y indicate mounting holes.

† Some applications require a clutch/reduction unit.

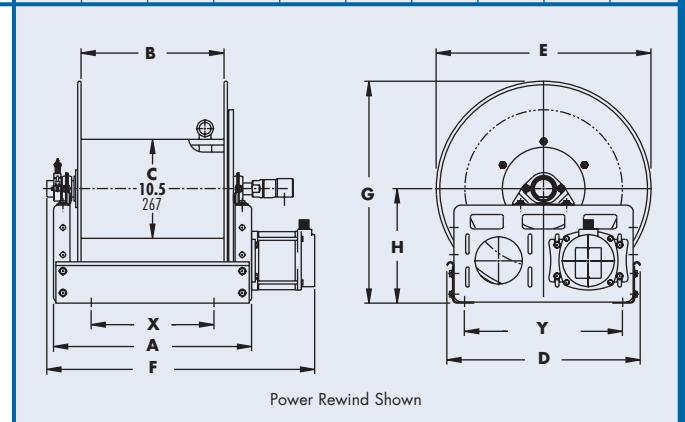

# 1100

## PORTABLE HOSE REELS ON WHEELS

To handle 3/8" through 5/8" I.D. hose.

- Continuous flow reels with swivel joint inlet, fluid hub, outlet riser.
- Comes with cam-lock brake.
- Direct crank rewind.
- One-piece foot, rubber tires and removable steel handlebar.
- Permanently attached crank.
- Standard inlet 90° ball bearing swivel joint 1/2" female NPT threads.
- Standard outlet is 1/2" female NPT threads.
- Pressures to 3000 psi (207 bar).
- Temperatures from +20° F to +400° F (-7° C to +204° C).
- Optional GH Prefix to model # (e.g. GH1100) includes garden hose thread on outlet, 5' lead-in hose, and hose end clips.



For:

- Grounds Maintenance
- Restaurants/Hotels
- Home Use

### Parts Drawing – ISO 48

Model Number	Hose Capacity of Reel				Approx. Weight		Reel Dimensions							
		feet			lb.		inches							
	I.D. (in) I.D. (mm)	3/8" 10	1/2" 13	5/8" 16	NET	SHIP	A	B	C	D	E	F	G	H
1100	O.D. (in) O.D. (mm)	3/4" 19	7/8" 22	1" 25	47 21	50* 23	21.5 546	12 305	6 152	22 559	16.5 419	24.62 625	39 991	13.81 351

**Notes:**

1. Specifications subject to change.
2. **Finish:** refer to Page 7.
3. **Be sure to check dimensions and weights prior to ordering.**  
\* When shipped as a parcel package (via FedEx or UPS Ground).

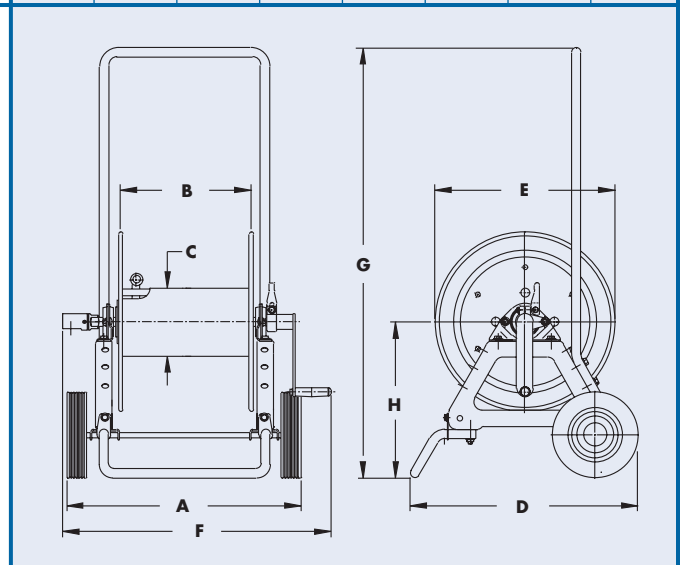

# AT1200

## PORTABLE HOSE REELS ON WHEELS

To handle 1/2" through 1" I.D. hose.

- Continuous flow reels with swivel joint inlet, fluid hub, outlet riser.
- Standard with cam-lock brake, and pneumatic tires.
- Direct crank rewind.
- One-piece foot, and removable steel handlebar.
- Permanently attached crank.
- Model AT1200 –standard inlet 90° balance pressure swivel joint 1" female NPT threads.
- Standard outlet is 1" female NPT threads.
- Operates at pressures to 1000 psi.
- Temperatures from -40° F to +250° F (-40° C to +121° C).
- Consult factory for other pressures & temps.
- Optional GH Prefix to model # (e.g. GHAT1200) includes garden hose thread on outlet, 5' lead-in hose, hose end clips.



GHAT 1200 Configuration Shown

**For:**

- Grounds Maintenance
- Restaurants/Hotels
- Home Use
- Construction

### Parts Drawing – ISO 87

Model Number	Hose Capacity of Reel					Approx. Weight		Reel Dimensions							
		feet				lb.		inches							
	I.D. (in) I.D. (mm)	1/2" 13	5/8" 16	3/4" 19	1" 25			A	B	C	D	E	F	G	H
AT1200	O.D. (in) O.D. (mm)	7/8" 22	1" 25	1-9/32" 33	1-9/16" 40	86 39	91* 41	24.88 632	11.5 292	8 203	23 584	22.75 578	26.5 673	40 1016	17.25 438

**Notes:**

1. Specifications subject to change.
2. **Finish:** refer to Page 7.
3. **Be sure to check dimensions and weights prior to ordering.**  
\* When shipped as a parcel package (via FedEx or UPS Ground).

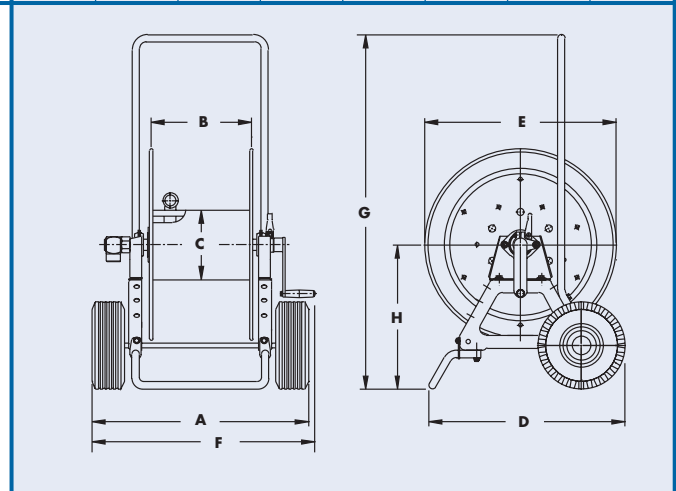



# REMOTE CONTROLLED POWER REWIND REELS

To handle single 3/8" through 1/2" I.D. hose.

- Heavy-duty 12V DC 1/3 HP Electric Reel.
- Bi-directional Remote Control (Power In, Power Out) with over 2,000 ft. range.
- Variable Speed Control allows user to choose comfortable unwind/rewind speed.
- Robust Remote Control with belt clip is weather and impact resistant.
- ALL rewind, unwind, and speed control functions are controllable from either remote control or base station.
- Optional Emergency Stop button allows engine/pump to be turned off remotely.
- Fully adjustable brake prevents hose movement during transit
- Standard inlet is 90° ball bearing swivel joint with 1/2" female NPT threads.
- Standard outlet is 3/4" male garden thread (other outlet threads available at no extra charge).
- Pressures to 3,000 psi (207 bar).
- Temperatures from +20°F to +400° (-7°C to +204°C).
- Choice of silver or black paint finish.

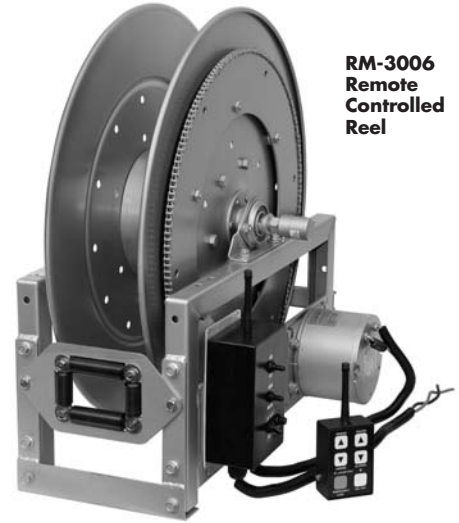

**RM-3006**  
Remote  
Controlled  
Reel



**RM-3006**  
Shown with  
300 ft. of  
3/8" hose  
(not included)

Other Control Features: The RM motor controllers have no electromechanical components that can break (relays, solenoids, circuit breakers). All functions are performed with state-of-the-art, military grade, environmentally sealed electronics. Over current, over temperature, and under voltage protection are all built into the electronics to ensure controller longevity. Automatic remote shut-off after 30 minutes. Proprietary software and controls to eliminate all wireless interference. Speed control settings are adjustable while reel is operational and controller will remember last setting even when powered off.

## Parts Drawing – ISO 221

Model Number	Hose Capacity of Reel		Approx. Weight		Reel Dimensions***										
	feet m.		lb. kg.		inches mm. Note 1 inch = 25.4mm										
	I.D. (in) I.D. (mm)	3/8" 10	1/2" 13	NET	SHIP	A	B	C	D	E	F	G	H	X	Y
RM-3006	O.D. (in) O.D. (mm)	5/8" 16	7/8" 22			103 47	138 63	10.5 267	5.5 140	8 203	27 686	26.75 679	16.5 419	28.25 718	14.88 378
RM-3008		500 152	300 91	110 50	145 66	10.5 267	5.5 140	10.5 267	31.5 800	31.75 806	16.5 419	33.63 854	17.75 451	5.75 146	27.75 705

**Notes:**

1. Specifications subject to change.
  2. Be sure to check dimensions and weights prior to ordering.
  3. Above reels can not be shipped via parcel post (UPS or FedEx Ground).
- NOTICE:** A Flexible Connector must be used between the inlet pipe and the inlet swivel joint.
- \*\*\* x,y indicate mounting holes.

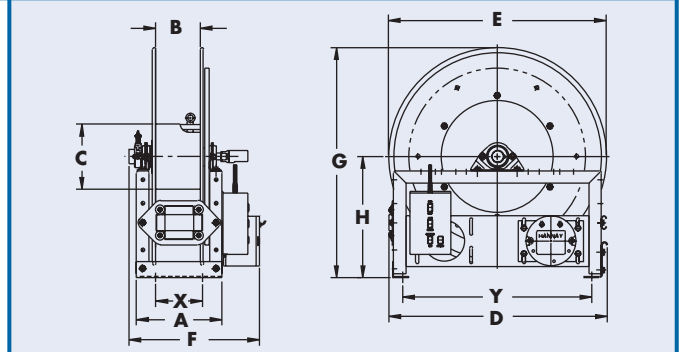



**Hannay Reels, Inc.** Phone 518797-3791 Toll Free 1-877-GO REELS (467-3357)  
FAX 1-800-REELING (733-5464) USA or FAX 518-797-3259 (International) [www.hannay.com](http://www.hannay.com) [reels@hannay.com](mailto:reels@hannay.com)

**World-class: Hannay will go to any length to provide you with the quality pressure and spray hose reels you need.**

As the world's leading manufacturer of hose and cable reels, Hannay knows what you need from both a pressure washing and spray hose reel. You need a reel that's long-lasting. Built to high standards. One that requires only minimal routine maintenance. That can stand up to demanding applications – season after season. A reel that helps you get the job done.

We make Hannay reels for the long run with leading-edge technology and the finest craftsmanship. Reels are all we make, so we do it the right way, from start to finish. From machining a one-piece axle hub, to testing parts before and after they go into our reels, you can count on world-class quality that only Hannay can deliver.

Hannay reels are versatile enough to handle anything from grounds and vehicle maintenance to lawn care, pest control, steam cleaning, washdown, pressure washing, chemical transfer, and spray painting. We have thousands of standard models and configurations. If one of these doesn't meet your needs, we'll work with you to design a reel that fits your specific application.



*Family owned and operated since 1933, Hannay Reels is the world leader in both OEM and aftermarket applications. Hannay offers thousands of standard hose reel and cable reel models, as well as unmatched custom capabilities. We can easily and affordably customize a reel to meet your exact specifications – built to last, delivered fast. Additional catalogs are available through your local Hannay Reels dealer or online at [www.hannay.com](http://www.hannay.com).*



553 State Route 143 • Westerlo, New York 12193-0159  
Toll Free Phone: **877**-467-3357 • Toll Free Fax: 800-733-5464

E-mail: [reels@hannay.com](mailto:reels@hannay.com)

Intl. Phone: 1-518-797-3791 • Intl. Fax: 1-518-797-3259

**[www.hannay.com](http://www.hannay.com)**



MADE IN U.S.A.