

FAMILY OWNED AND OPERATED SINCE 1933

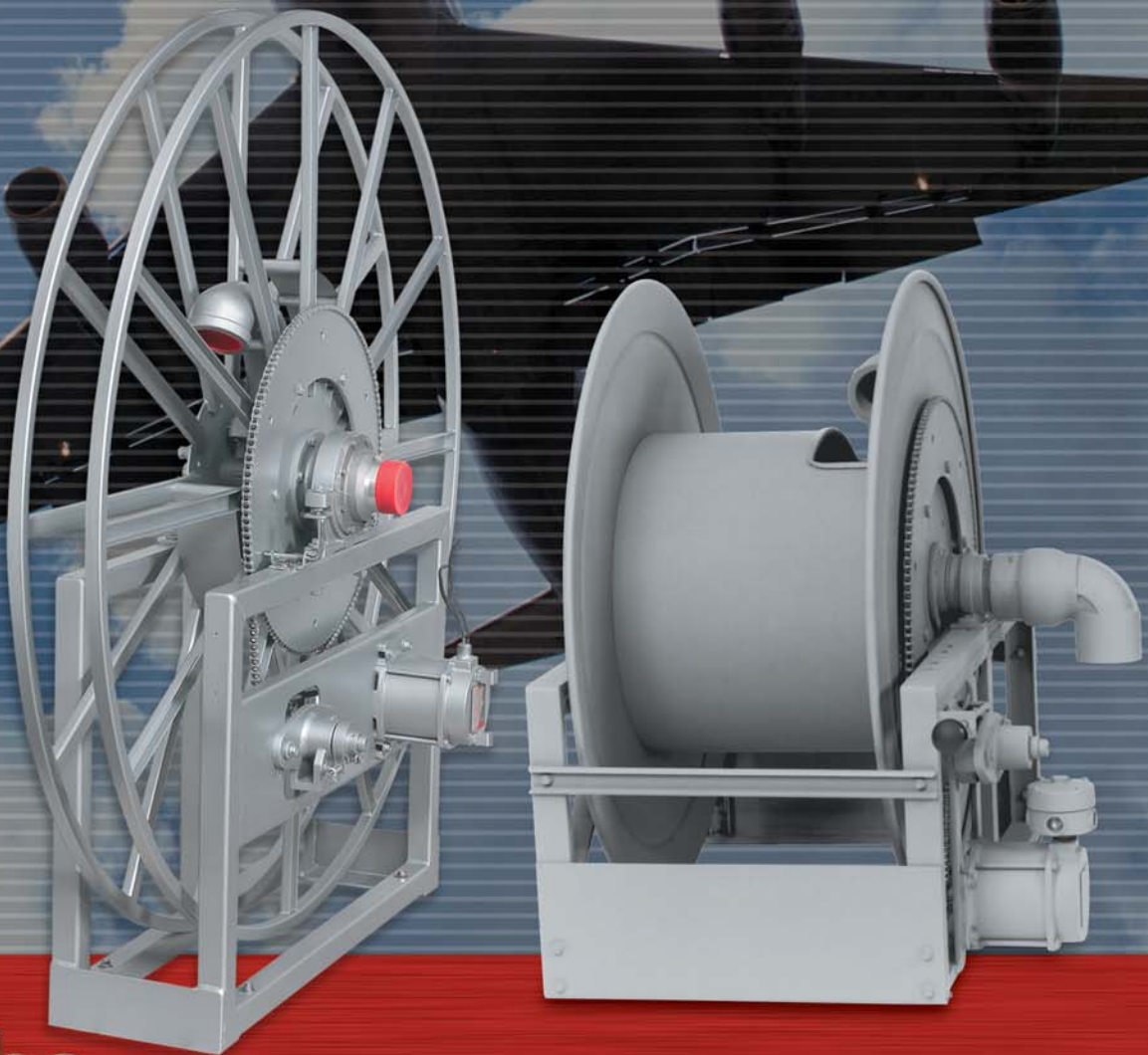

Hannay Reels®
The reel leader.

Aviation Reels



The
Hannay
Way

Refueling • Airport Hydrant Fueling Operations
Sensing • Static Grounding

www.hannay.com

Pride in workmanship • Reels built to order • Consistent quality • Service with integrity • Value for your dollar

Note to Designers and Engineers:

The reels shown in this catalog are the standard of the industry. These models reflect various installation and performance requirements.

The high quality of our standard steel construction is only the beginning.

Hannay Reels offers any size configuration to fit a defined space, and we construct many models of reels of aluminum or stainless steel. Specifically, we use 5000 and 6000 Series aluminum and 304 stainless steel in the manufacture of frames, discs, drums and internals as well as other structural components. This type of construction eliminates the need for maintenance repainting and part replacement due to rust or corrosion.

The drum diameters of the reel models listed have been used successfully for many years. However if your application requires a larger drum diameter to meet **API hose standards**, please remember it will also *increase the envelope dimensions* for the reel and *may incur an extra cost*.

Please note: Jet fuels require non-ferrous internal piping.

Hannay Reels offers aluminum or stainless steel internals for 1" to 4" I.D. hose reels.

Please consult factory on any fuel handling questions.

For the many accessories and components available on our standard reel models such as roller guides, switches, brakes and locks, etc., please refer to our Ordering & Accessory Guide H-0415-OA.

Paint Notice

To meet the requirements and performance of vehicle and OEM apparatus paints we recommend our reels be painted with the same or equal paint as used on the specific apparatus the reel is being mounted on.

Hannay Reels will supply any model or custom reel or part with an automotive primer or rust preventative oil finish upon request, allowing application of final coating at your facility. Or at additional cost Hannay can prime / pre-paint all material before final assembly.

In today's regulatory environment this would be the most cost-effective way to meet your finishing standards.

Consult factory for other optional finishes

Standard finish is oven cured enamel. High performance finishes for demanding and corrosive environments are available at an additional cost. Consult factory for specific requirements.

S E R I E S

1 1/2"

MANUAL OR POWER REWIND REELS

To handle single 1" through 1-1/2" I.D. hose.

- A strong, heavy-duty reel.
- Gear-driven crank rewind or chain and sprocket drive powered by an electric, hydraulic or compressed air motor.
- Optional auxiliary crank rewind for power rewind reels.
- Crank rewind reels supplied with pinion brake and power rewind reels with a comet brake.
- 90° ball bearing swivel joint with 1-1/2" female NPT threads and 2" victaulic groove.
- Flanged riser with 1-1/2" female NPT threads.
- Other sizes and/or threads can be furnished and must be specified.
- Standard inlet, outlet riser, hub assembly are aluminum for jet fuels.
- Stainless steel, at extra cost.
- Rollers and roller mounting brackets are accessory items. Specify roller position.
- Pressures to 600 psi (41 bar)
- Temperatures from -40°F to +175°F (-40° C to +79° C).
- Consult factory for other pressures & temps.

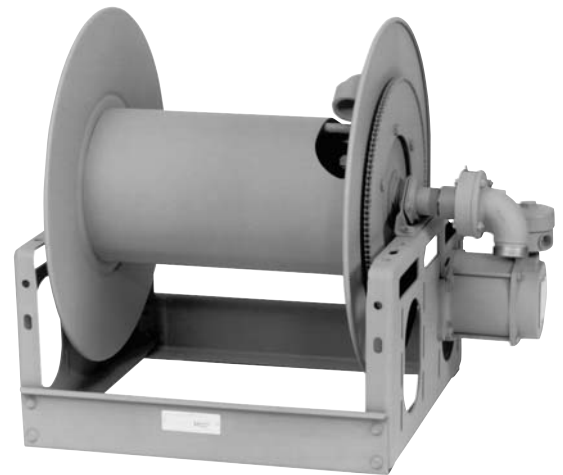

Standard Configuration
Shown

Hannay Reels, Inc. Phone 518-797-3791 Toll Free 1-877-GO REELS (467-3357)

FAX 1-800-REELING (733-5464) USA or FAX 518-797-3259 (International) www.hannay.com reels@hannay.com

Parts Drawing – ISO 18

Model Number	Hose Capacity of Reel feet m.				Approx. Weight Crank Rewind lb. kg. See Note 4		Reel Dimensions*** inches mm.										
	I.D. (in) I.D. (mm)	1" 25	1-1/4" 32	1-3/8" 35	1-1/2" 38	NET	SHIP	A	B	D	E	F crank	F power	G	H	X	Y
	O.D. (in) O.D. (mm)	1.58" 40	1.89" 48	2" 51	2.06" 52												
26-19-21		70 21	60 18	50 15	50 15	99 45	141 64	23 584	17.5 445	20.5 521	18.75 476	29.5 749	31.88 810	21.5 546	12.12 308	15 381	16.75 425
32-19-21		100 30	90 27	85 26	75 23	112 51	154 70	29.5 749	24 610	20.5 521	18.75 476	36.0 914	38.38 975	21.5 546	12.12 308	21.5 546	16.75 425
40-19-21		125 38	100 30	100 30	100 30	128 58	170 77	37.5 953	32 813	20.5 521	18.75 476	44.0 1118	46.38 1178	21.5 546	12.12 308	29.5 749	16.75 425
24-23-24		100 30	90 27	80 24	50 15	102 46	144 65	21 533	15.5 394	20.5 521	22.75 578	27.5 699	29.88 759	23.5 597	12.12 308	13 330	16.75 425
32-23-24		150 46	150 46	125 38	75 23	119 54	161 73	29.5 749	24 610	20.5 521	22.75 578	36.0 914	38.38 975	23.5 597	12.12 308	21.5 546	16.75 425
38-23-24		200 61	190 58	170 52	100 30	130 59	172 78	35 889	29.5 749	20.5 521	22.75 578	41.5 1054	43.88 1115	23.5 597	12.12 308	27 686	16.75 425
20-25-26		110 34	70 21	60 18	50 15	106 48	148 67	17 432	11.5 292	25.5 648	24.75 629	23.5 597	25.88 657	27.88 708	15.5 394	9 229	21.75 552
24-25-26		140 43	95 29	85 26	75 23	114 52	156 71	21 533	15.5 394	25.5 648	24.75 629	27.5 699	29.88 759	27.88 708	15.5 394	13 330	21.75 552
28-25-26		200 61	130 40	120 37	100 30	123 56	165 75	25.5 648	20.0 508	25.5 648	24.75 629	32.0 813	34.38 873	27.88 708	15.5 394	17.5 445	21.75 552
16-30-31		90 27	50 15	50 15	50 15	106 48	156 71	13 330	7.5 191	25.5 648	28.75 730	19.5 495	21.88 556	29.88 759	15.5 394	7.75 197	21.75 552
20-30-31		155 47	140 43	80 24	75 23	114 52	164 74	17 432	11.5 292	25.5 648	28.75 730	23.5 597	25.88 657	29.88 759	15.5 394	9 229	21.75 552
*22-30-31		185 56	160 49	100 30	100 30	118 54	168 76	19 483	13.5 343	25.5 648	28.75 730	25.5 648	27.88 708	29.88 759	15.5 394	11 279	21.75 552
*28-30-31		275 84	250 76	175 53	150 46	131 59	181 82	25.5 648	20.0 508	25.5 648	28.75 730	32.0 813	34.38 873	29.88 759	15.5 394	17.5 445	21.75 552
*24-33-34		275 84	190 58	175 53	175 53	129 59	179 81	20.5 521	15.5 394	31.5 800	31.75 806	27.25 692	29.63 753	33.62 854	17.75 451	13 330	27.75 705

Notes:

- Specifications subject to change.
- Upon request, reels can be supplied with drum lengths other than shown and with disc sizes in other diameters.
- Dimensions shown for reels up to and including 30-31 disc size reflect pressed frames. All others are channel frames.
- Weights shown in chart are for crank rewind models. ADD these amounts for power rewind models:

	Net (lbs.)	Ship (lbs.)	Net (kg.)	Ship (kg.)
Electric	40	40	18.1	18.1
Hydraulic	20	20	9.1	9.1
Air	20	20	9.1	9.1

- When ordering power rewind models, prefix model number with:
 A = Air Rewind–Supplied with control valve and hose.
 EPJ = Explosion Proof Electric Rewind (1/2 HP)–Supplied with explosion proof switch, solenoid, and junction box.
 HD = Hydraulic Rewind–Not supplied with control valve.
- For Air Rewind on models over 100 ft. of 1-1/2" consult factory.
- Be sure to check dimensions and weights prior to ordering.**

NOTICE: A Flexible Connector must be used between the inlet pipe and the inlet swivel joint.

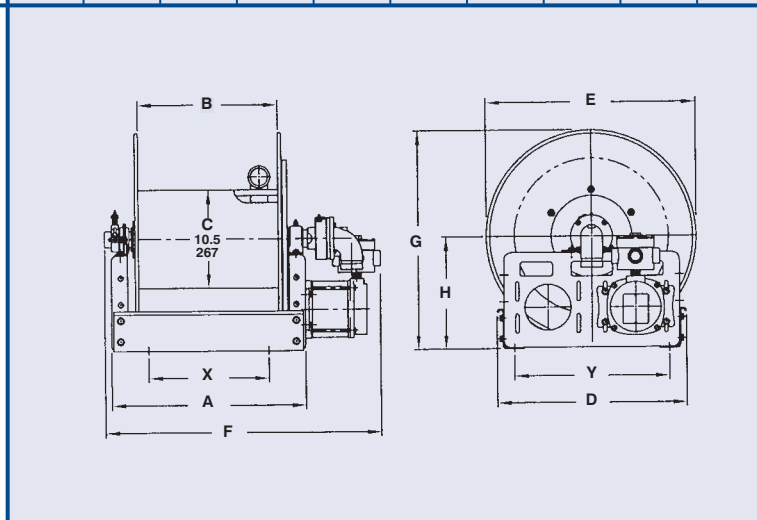

* Some applications may require a different motor and/or a clutch/reduction unit.

***x,y indicate mounting holes.

2"

MANUAL OR POWER REWIND REELS

To handle single 1-1/2" or 2" I.D. hose.

- Gear-driven crank rewind, or chain and sprocket drive powered by an electric, hydraulic or compressed air motor.
- Optional auxiliary crank rewind for power reels.
- Crank rewind reels supplied with pinion brake and power rewind reels with a comet brake.
- 90° ball bearing swivel joint with 2-1/2" victaulic.
- Flanged riser with 2" female NPT threads.
- Other sizes and/or threads can be furnished and must be specified.
- Standard inlet, riser, hub assembly are aluminum for jet fuels.
- Stainless steel, at extra cost.
- Rollers and roller mounting brackets are accessory items. Specify roller position.
- Pressures to 150 psi (10 bar).
- Temperatures from -20° F to +225° F (-29° C to +107° C).
- Consult factory for other pressures & temps.

- Recommended on reels with 39" diameter or larger discs, or when increased torque, and slower rewind speeds are required.
- Factory-installed.



Standard Configuration Shown

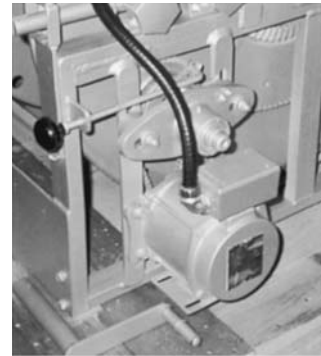

Chain Clutch - Reduction Units

Parts Drawing – ISO 35

Model Number	Hose Capacity of Reel			Approx. Weight		Reel Dimensions***									
	feet			Crank Rewind		inches									
	m.			lb.		mm.									
For Power Rewind See Notes 3 & 4	I.D. (in)	1-1/2"	2"	NET	SHIP	A	B	D	E	F CRANK	F POWER	G	H	X	Y
	I.D. (mm)	38	51												
232-26-27		70	50	104	154	23.75	17.5	27	25.75	31	31.63	26.62	13.75	16.25	23.25
		21	15	47	70	603	445	686	654	787	803	676	349	413	591
238-26-27		100	75	145	195	30.25	24	27	25.75	37.5	38.13	26.62	13.75	22.75	23.25
		30	23	66	88	768	610	686	654	953	969	676	349	578	591
246-26-27		140	100	196	246	38.25	32	27	25.75	45.5	46.13	26.62	13.75	30.75	23.25
		43	30	89	112	972	813	686	654	1156	1172	676	349	781	591
224-33-34		60	50	70	140	15.75	9.5	31.5	31.75	23	23.63	33.38	17.5	8.25	27.75
		18	15	32	64	400	241	800	806	584	600	848	445	210	705
228-33-34		100	75	92	162	19.75	13.5	31.5	31.75	27	27.63	33.38	17.5	12.25	27.75
		30	23	42	73	502	343	800	806	686	702	848	445	311	705
234-33-34		140	100	133	203	26.25	20	31.5	31.75	33.5	34.13	33.38	17.5	18.75	27.75
		43	30	60	92	667	508	800	806	851	867	848	445	476	705
232-39-40		250	150	180	250	23.75	17.5	40	39	31	33	39.88	20.38	16.25	37
		76	46	82	113	603	445	1016	991	787	838	1013	518	413	940
240-39-40		350	200	218	288	32.25	26	40	39	39.5	41.5	39.88	20.38	22.75	37
		107	61	99	131	819	660	1016	991	1003	1054	1013	518	578	940

Notes:

- Specifications subject to change.
- Upon request, reels can be supplied with drum lengths other than shown and with disc sizes in other diameters.
- Weights shown in chart are for crank rewind models. ADD these amounts for power rewind models:

	Net (lbs.)	Ship (lbs.)	Net (kg.)	Ship (kg.)
Electric	40	40	18.1	18.1
Hydraulic	20	20	9.1	9.1
Air	20	20	9.1	9.1
- When ordering power rewind models, prefix model number with:
 - A = Air Rewind–Supplied with control valve and hose.
 - EPJ = Explosion Proof Electric Rewind (1/2 HP)–Supplied with explosion proof switch, solenoid, and junction box.
 - HD = Hydraulic Rewind–Not supplied with control valve.

5. Be sure to check dimensions and weights prior to ordering.

NOTICE: A Flexible Connector must be used between the inlet pipe and the inlet swivel joint.

***x,y indicate mounting holes.

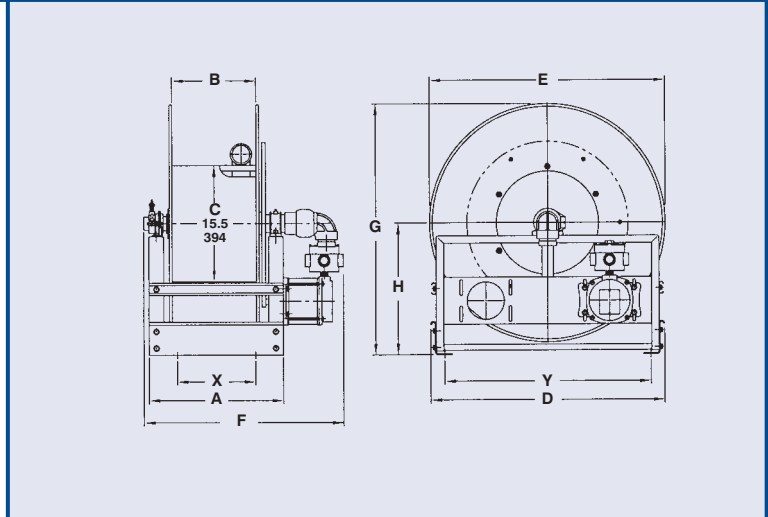

3"

MANUAL OR POWER REWIND REELS

To handle 2" through 3" I.D. hose.

- Rugged, industrial-duty channel frame construction.
- Gear-driven crank rewind or chain and sprocket drive powered by an electric, hydraulic or compressed air motor.
- Pinion shaft brake as auxiliary crank rewind on power reels, at extra cost.
- Crank rewind supplied with pinion brake, power reels with comet brake. Other brakes and locking devices may be specified.
- 90° ball bearing swivel joint with 3" victaulic groove.
- Flanged riser with 3" female NPT threads.
- Consult factory for other sizes and/or threads.
- Standard inlet, outlet riser and hub assembly are aluminum for jet fuels.
- Rollers and roller mounting brackets are accessory items. Specify roller position.
- Pressures to 150 psi (10 bar)
- Temperatures from -20° F to +225° F (-29° C to +107° C).
- Consult factory for other pressures and temperatures.

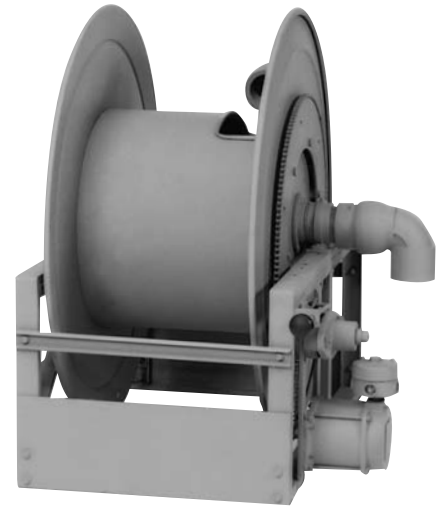

Shown with Clutch-Reduction unit



Chain Clutch - Reduction Units

- Standard on reels with 39" diameter or larger discs, or when increased torque and slower rewind speeds are required.
- Factory-installed.

Parts Drawing – ISO 57

Model Number	Hose Capacity of Reel				Approx. Weight Crank Rewind See Note 3		Reel Dimensions***													
	feet m.				NET	SHIP	inches mm.													
	I.D. (in) I.D. (mm)	2" 51	2-1/2" 64	3" 76			A	B	C	D	E	F CRANK	F POWER	G	H	X	Y			
For Power Rewind See Notes 3 & 4	O.D. (in) O.D. (mm)	2.67 68	3.25 83	3.78 96																
		50 15	*25 8	— —	116 53	166 75	26.25 667	20 508	15.5 394	27 686	27.38 695	35.75 908	36.25 921	27.12 689	14.25 362	18.75 476	23.25 591			
340-26-27		85 26	*35 11	— —	153 69	203 92	32.25 819	26 660	15.5 394	27 686	27.38 695	41.75 1060	42.25 1073	27.12 689	14.25 362	24.75 629	23.25 591			
350-26-27		100 30	*50 15	— —	213 97	340 155	42.25 1073	36 914	15.5 394	27 686	27.38 695	51.75 1314	52.25 1327	27.12 689	14.25 362	34.75 883	23.25 591			
332-33-34		70 21	25 8	25 8	125 57	195 88	23.75 603	17.5 445	20 508	31.5 800	31.75 806	33.25 845	33.75 857	33.88 861	18 457	16.25 413	27.75 705			
346-33-34		140 43	50 15	50 15	237 108	307 139	38.25 972	32 813	20 508	31.5 800	31.75 806	47.75 1213	48.25 1226	33.88 861	18 457	30.75 781	27.75 705			
332-39-40		120 37	65 20	50 15	201 91	271 123	23.75 603	17.5 445	20 508	40 1016	39 991	33.25 845	33.75 857	40.38 1026	20.88 530	16.25 413	37 940			
338-39-40		185 56	90 27	80 24	239 108	309 140	30.25 768	24 610	20 508	40 1016	39 991	39.75 1010	40.25 1022	40.38 1026	20.88 530	22.75 578	37 940			
334-45-46		200 61	120 37	100 30	361 164	431 195	26.25 667	20 508	20 508	46 1168	45 1143	35.75 908	36.25 921	46.38 1178	23.88 607	18.75 476	43 1092			

Notes:

- Specifications subject to change.
- Upon request, reels can be supplied with drum lengths other than shown and with disc sizes in other diameters.
- Weights shown in chart are for crank rewind models. ADD these amounts for power rewind models:

	Net (lbs.)	Ship (lbs.)	Net (kg.)	Ship (kg.)
Electric	40	40	18.1	18.1
Hydraulic	20	20	9.1	9.1
Air	20	20	9.1	9.1

- When ordering power rewind models, prefix model number with:
 A = Air Rewind—Supplied with control valve and hose.
 EPJ = Explosion Proof Electric Rewind (1/2 HP)—Supplied with explosion proof switch, solenoid, and junction box.
 HD = Hydraulic Rewind—Not supplied with control valve.

5. Be sure to check dimensions and weights prior to ordering.

NOTICE: A Flexible Connector must be used between the inlet pipe and the inlet swivel joint.

*Be sure to verify bend radius of hose before ordering.

***x, y indicate mounting holes.

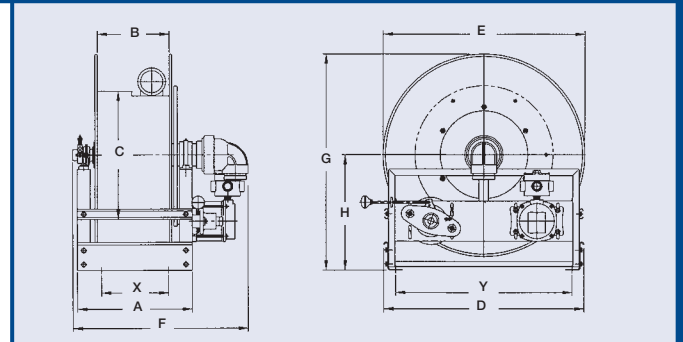

4"

MANUAL OR POWER REWIND REELS

To handle 3" or 4" I.D. hose.

- *Rugged, industrial-duty channel frame construction.*
- *Gear-driven crank rewind, or chain and sprocket drive powered by an electric, hydraulic or compressed air motor.*
- *Pinion shaft brake as auxiliary on power reels, at extra cost.*
- *Crank rewind reels supplied with pinion brake, power reels with comet brake. Other brakes and locking devices may be specified.*
- *90° ball bearing swivel joint with 4" female NPT threads.*
- *Flanged riser with 4" female NPT threads.*
- *Consult factory for other sizes and/or threads.*
- *Standard outlet riser and hub assembly are steel with iron inlet swivel joint. For jet fuels can be supplied in stainless steel, at extra cost.*
- *Rollers and roller mounting brackets are accessory items. Specify roller position.*
- *Pressures to 150 psi (10 bar)*
- *Temperatures from -20° F to +225° F (-29° C to +107° C).*
- *Consult factory for other pressures and temperatures.*

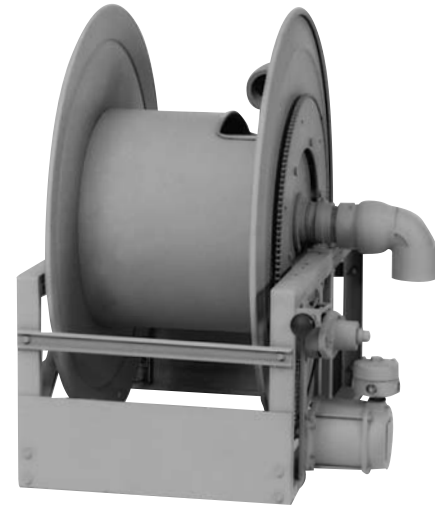

Standard Configuration Shown



Chain Clutch - Reduction Units

- *Standard on all 4" Series reels for increased torque and slower rewind speeds as required.*

5000

SINGLE WRAP POWER REWIND REELS

To handle single 1-1/2" I.D. through 3" I.D. hose.

- Effortless and fast rewinding, wrapping, guiding of hose.
- Chain and sprocket drive powered by electric, hydraulic, or compressed air motor.
- Auxiliary crank rewind, optional.
- 12 volt rewind, comet brake, reduction unit standard.
- Air brake optional.
- Inlet, hub assembly is aluminum and/or stainless steel for jet fuel.
- Consult factory for other pressures & temps.

Series 5100

- 90° ball bearing swivel joint 1-1/2" female NPT threads, 2" victaulic groove, flanged riser with 1-1/2" female NPT threads.
- Pressures to 600 psi (41 bar).
- Temperatures from -40° F to +175° F (-40° C to +79° C).

Series 5200

- 90° ball bearing swivel joint 2-1/2" victaulic groove, flanged riser with 2" female NPT threads.
- Pressures to 150 psi (10 bar).
- Temperatures from -20° F to +225° F (-29° C to +107° C).

Series 5300

- 90° ball bearing swivel joint 3" victaulic groove, flanged riser with 3" female NPT threads.
- Pressures to 150 psi (10 bar).
- Temperatures from -20° F to +225° F (-29° C to +107° C).



Standard Model Shown
(Hose not included)



Option: Victaulic Version
I-hub for 5300 Series

5000

Parts Drawing – ISO 197

Model Number	Hose Capacity of Reel feet m.					Approx. Weight lb. kg.		Reel Dimensions inches mm.						
	I.D. (in) I.D. (mm)	1-1/2" 38	2" 51	2-1/2" 64	3" 76	NET	SHIP	A	B	C	E	F POWER	G	H
	O.D. (in) O.D. (mm)	2.06 52	2.67 68	3.25" 83	3.78" 96									
5111-48-50-20		50 15	— —	— —	— —	310 141	385 175	11 279	2.75 70	20 508	48 1219	17.5 445	50 1270	26 660
5111-56-58-20		75 23	— —	— —	— —	330 150	405 184	11 279	2.75 70	20 508	56 1422	17.5 445	58 1473	30 762
5111-62-64-20		100 30	— —	— —	— —	340 154	415 188	11 279	2.75 70	20 508	62 1575	17.5 445	64 1626	33 838
5111-72-74-20		130 40	— —	— —	— —	350 159	425 193	11 279	2.75 70	20 508	72 1829	17.5 445	74 1880	38 965
5218-56-58-24		— —	50 15	— —	— —	370 168	445 202	12 305	3.75 95	24 610	56 1422	19.25 489	58 1473	30 762
5218-62-64-24		— —	75 23	— —	— —	390 177	465 211	12 305	3.75 95	24 610	62 1575	19.25 489	64 1626	33 838
5218-70-72-24		— —	100 30	— —	— —	400 181	475 215	12 305	3.75 95	24 610	70 1778	19.25 489	72 1829	37 940
5319-62-64-30		— —	— —	50 15	50 15	400 182	475 216	13 330	4.75 121	30 762	62 1575	21.25 540	64 1626	33 838
5319-70-72-30		— —	— —	75 23	— —	410 186	485 220	13 330	4.75 121	30 762	70 1778	21.25 540	72 1829	37 940
5319-78-80-30		— —	— —	100 30	— —	420 191	495 225	13 330	4.75 121	30 762	78 1981	21.25 540	80 2032	41 1041

Notes:

- Specifications subject to change.
- When ordering power rewind models, prefix model number with:
A = Air Rewind EP = Electric Rewind (1/2 HP) HD = Hydraulic Rewind
(Air rewind reels are supplied with control valve and hose;
12v and 24v DC rewind reels are supplied with switch and solenoid;
hydraulic rewind reels are not supplied with control valve.)

3. Be sure to check dimensions and weights prior to ordering.

NOTICE: A Flexible Connector must be used between the inlet pipe and the inlet swivel joint.

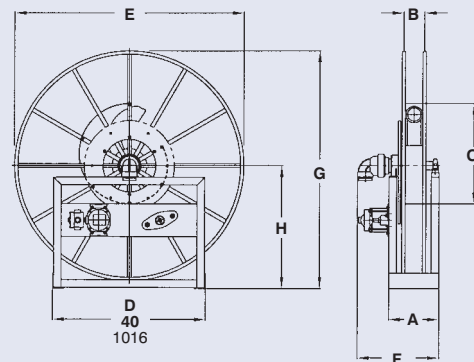

N600

SPRING REWIND DUAL HOSE REELS

To handle dual 1/4" through 3/8" I.D. sensing hose.

- Narrow frame and compact mounting base.
- Non sparking ratchet assembly.
- Declutching arbor to prevent damage from reverse winding.
- Standard inlets 90° balanced pressure swivel joints 1/2" female NPT threads.
- Standard outlets 1/2" female NPT threads.
- Pressures to 3000 psi (207 bar)
- Temperatures from -60° F to +250° F (-51°C to +121°C).
- Consult factory for other pressures & temps.
- 4-way roller assembly. Specify roller position.
- Constant Tension is available – consult factory.

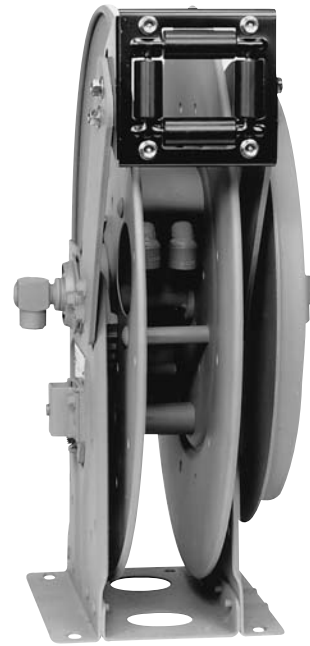

Optional TR roller position shown

Parts Drawing – ISO 80

Model Number	Hose Capacity of Reel feet m.			Approx. Weight lb. kg.		Standard Roller Assy	Reel Dimensions*** inches mm.							
	I.D. (in) I.D. (mm)	1/4" 6	3/8" 10	NET	SHIP		N/A	B	C	N/E	N/F	N/G	N/H	N/X
*N616-19-20-10.5C	O.D. (in) O.D. (mm)	.53" 13	.66" 17			70 32	105 48	N204	10 254	4 102	10.5 267	20.75 527	12.75 324	20 508
*N616-19-20-8J		2/25 2/8	2/25 2/8	74 34	109 49	N204	10 254	4 102	8 203	20.75 527	12.75 324	20 508	10.62 270	8 203
*N616-23-24-10.5G		2/50 2/15	2/50 2/15	94 43	129 59	N204	10 254	4 102	10.5 267	23.75 603	12.75 324	24 610	12.62 321	8 203
*N617-23-24-10.5G		2/75 2/23	2/75 2/23	95 43	130 59	N205	11 279	5 127	10.5 267	23.75 603	13.75 349	24 610	12.62 321	9 229

Notes:

1. Specifications subject to change.
2. Reel models and capacities shown are for standard drag applications; for vertical lift applications consult factory.
3. Other sizes, from standard components, available on request.
4. Be sure to check dimensions and weights prior to ordering.

NOTICE: A Flexible Connector must be used between the inlet pipe and the inlet swivel joint.

* When shipped as a parcel package add 16 to net wt. for shipping wt. (via Fed-Ex or UPS Ground).

*** x,y indicate mounting holes.

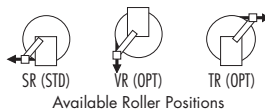
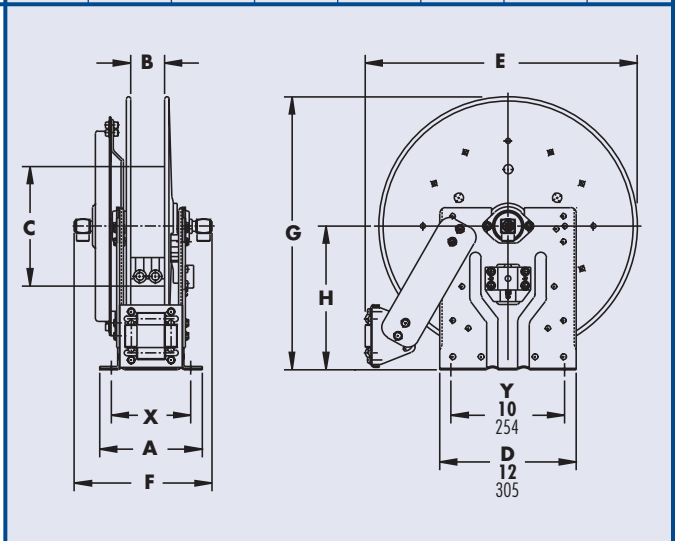

900

SPRING REWIND REELS

To handle 1-1/4" or 1-1/2" I.D. hose.

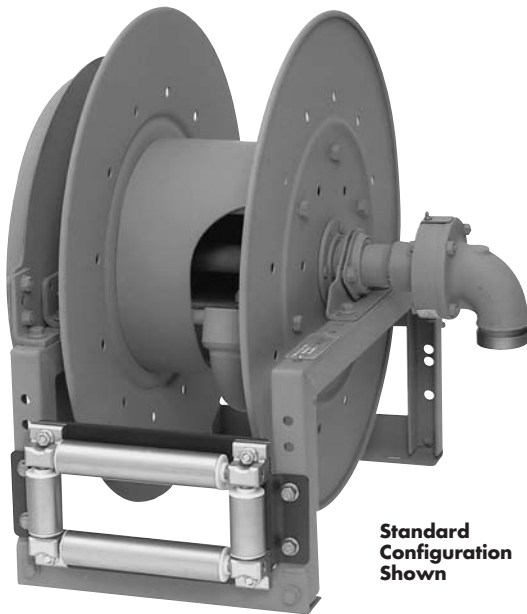

Standard Configuration Shown

- Rollformed channel frame construction.
- Non sparking ratchet assembly.
- Declutching arbor to prevent damage from reverse winding.
- Standard inlet 90° swivel joint 1-1/2" female NPT threads and 2" victaulic groove.
- Standard outlet 1-1/2" female NPT threads.
- Consult factory for other sizes and/or threads.
- Standard inlet, outlet riser, and hub assembly are aluminum for jet fuels.
- Pressures to 600 psi (41 bar)
- Temperatures from -40° F to +175° F (-40° C to +79° C).
- Consult factory for other pressures & temps.
- 4-way roller assembly.
- Constant Tension is available – consult factory.

Parts Drawing – ISO 29

Model Number	Hose Capacity of Reel			Weight		Standard Roller Assy	Reel Dimensions***								
	feet			lb.	SHIP		inches								
	I.D. (in)	1-1/4"	1-1/2"				mm.								
	I.D. (mm)	32	38	NET	SHIP		A	B	D	E	F	G	H	X	Y
	O.D. (in)	1-13/16"	2-1/16"												
	O.D. (mm)	46	52												
922-23-24B		40	25	104	139	R310	15.25	10	23.25	25.25	24	23.88	12.5	10.5	20.25
		12	8	47	63		387	254	591	641	610	607	318	267	514
920-25-26A		50	40	127	162	R308	13.25	8	25	27	22.75	25.88	13.5	8.5	22
		15	12	58	73		337	203	635	686	578	657	343	216	559
922-30-31A		75	50	156	191	R310	15.25	10	28.5	30.5	24.75	31.38	17	10.5	25.5
		23	15	71	87		387	254	724	775	629	797	432	267	648

Notes:

1. Specifications subject to change.
2. Reel models and capacities shown are for standard drag applications; for vertical lift applications consult factory.
3. Other sizes, from standard components, available on request.

4. Be sure to check dimensions and weights prior to ordering.

NOTICE: A Flexible Connector must be used between the inlet pipe and the inlet swivel joint.

*** x,y indicate mounting holes.

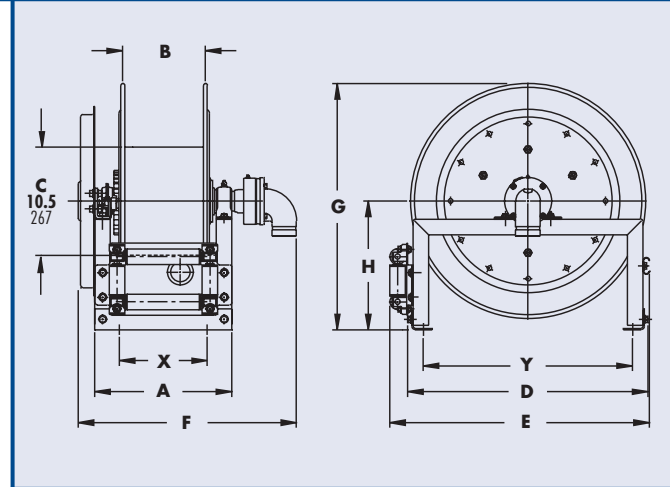

STATIC GROUNDING REELS

STATIC GROUNDING REELS FOR REFUELING OR HAZARADOUS AREAS

- Capacities of up to 200 feet of grounding cable.
- Ground aircraft, fuel trucks and other equipment during refueling.
- Spring motors provide smooth operation.
- Declutching arbor.
- Adjustable guide arm with cable guide.

WARNING
These Reels are for
Static Grounding ONLY
NOT intended for lightning protection!

Applications:

- Aircraft Refueling
- Chemical Transfer
- Rescue and Hazmat Operations



Model HGR50
shown with optional "Y" branch

Grounding Jack
per MIL-C-8341D/4
Part No. 9951.0033



Optional Browne Clamp
Part No. 9951.0031



Model HGR100
Standard configuration



Model GR75
Standard configuration



Model MHGR50-50



Model MGR75

STATIC GROUNDING REELS

Series GR

- 1/8", 7x19 galvanized carbon steel cable with 100 amp Alligator Clamp.
- Galvanized cable is standard. Optional plastic coated galvanized cable at no extra charge.
- Stainless steel plastic covered cable, "Y" branches are available additional charge.
- Permanently sealed spring.
- Standard finish is oven-cured enamel.
- Manual rewind version also available.

Series HGR

- 1/8", 7x19 galvanized carbon steel cable with 100 amp Alligator Clamp.
- Galvanized cable is standard. Optional plastic coated galvanized cable at no extra charge.
- Stainless steel plastic-covered cable, "Y" branches are available additional charge.
- Non-sparking ratchet.
- Standard finish is oven-cured enamel.
- Manual rewind version also available.

Parts Drawing – ISO 10 for HGR Series

Model Number	Cable Capacity of Reel $\frac{\text{feet}}{\text{m.}}$	Approx. Weight $\frac{\text{lb.}}{\text{kg.}}$		Reel Dimensions*** $\frac{\text{inches}}{\text{mm.}}$									
		Without Cable	With Cable	A	B	C	D	E	F	G	H	X	Y
GR 75	75 23	11	14	2	2	7	9	9.25	3.5	9.88	5.06	1	7.88
		5	6	51	51	178	229	235	89	251	129	25	200
MGR 75	100 30	11	13	2	2	7	9	9.25	5.25	9.88	5.06	1	7.88
		5	6	51	51	178	229	235	133	251	129	25	200
HGR 50	75 23	28	30	4	1.25	10.75	11.5	14.25	5.5	16.75	8.88	2.38	7.5
		13	14	102	32	273	292	362	140	425	226	60	191
MHGR 50	200 61	18	20	4	1.25	10.75	11.5	14.25	6.25	16.75	8.88	2.38	7.5
		8	9	102	32	273	292	362	159	425	226	60	191
HGR 100	100 30	37	40	4	1.25	13.25	11.5	16.75	5.5	17.75	8.88	2.38	7.5
		17	18	102	32	337	292	425	140	451	226	60	191

To Order (specify all items listed):

- Gauge, length, O.D., and coating if required
- Specify "Y" branch if required
- Finish if other than standard
- Complete model number

Reels can be shipped as a parcel package (via FedEx or UPS ground).

*** x,y indicate mounting holes.

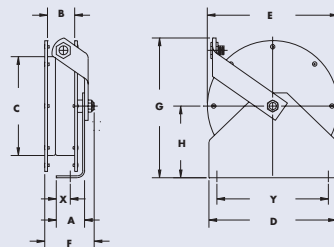

Models GR75/MGR75
GR75 Shown

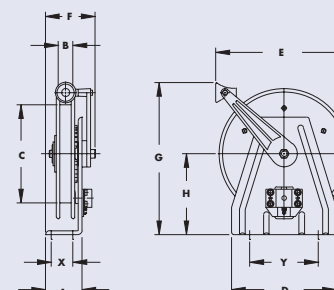

Models HGR50/
HGR100/MHGR50

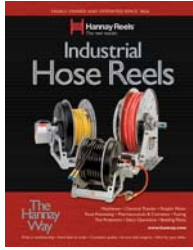

Hose Reels

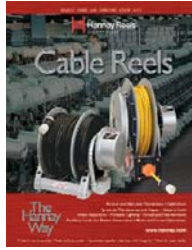

Cable Reels

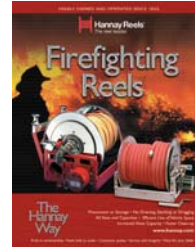

Firefighting Reels

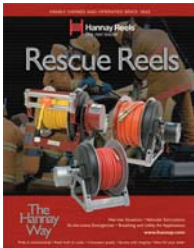

Rescue Reels

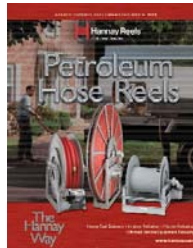

Petroleum Reels



LP Gas Reels



**Ordering &
Accessory Guide**



Family owned and operated since 1933, Hannay Reels is a leader in both OEM and aftermarket applications. Hannay offers thousands of standard hose reel and cable reel models, as well as unmatched custom capabilities. We can easily and affordably customize a reel to meet your exact specifications – built to last, delivered fast. Additional catalogs are available through your local Hannay Reels dealer or online at www.hannay.com.



553 State Route 143 • Westerlo, New York 12193-0159
Toll Free Phone: 1-877-GO REELS • Toll Free Fax: 1-800-REELING

E-mail: reels@hannay.com

Intl. Phone: 1-518-797-3791 • Intl. Fax: 1-518-797-3259

www.hannay.com



MADE IN U.S.A.